

# fermacell

## The Orange Book

April 2016

fermacell<sup>®</sup>









# Contents

|                     |    |
|---------------------|----|
| Fermacell           | 4  |
| Partitions          | 28 |
| Linings             | 54 |
| Flooring & Ceilings | 66 |
| Fix & Finish        | 78 |
| Wet Areas           | 90 |

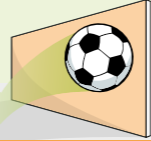
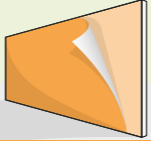
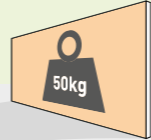
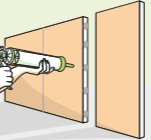
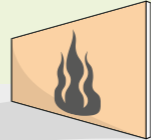

|                 |    |
|-----------------|----|
| The Company     | 5  |
| Fire            | 10 |
| Acoustics       | 11 |
| Impact          | 18 |
| Moisture        | 21 |
| Environmental   | 22 |
| Product Use     | 24 |
| Health & Safety | 26 |

**Fermacell at a glance.**

|  |   |
|--|---|
| <br><b>Environmentally Certified</b><br>Manufactured from recycled materials.   | <br><b>Sound Insulating</b><br>Simple Party Wall constructions.                                |
| <br><b>Impact Resistant</b><br>Reduces double layering or use of Sheathing Ply.   | <br><b>Ready to Decorate</b><br>Ready to accept paint, wallpaper, tiles.                       |
| <br><b>Load-carrying</b><br>Up to 50kg per cavity fixing and 30kg per screw. Eliminates Noggings.  | <br><b>Unique Jointing System</b><br>Glued, square edge boards produce a continuous membrane. |
| <br><b>Fire Resistant</b><br>60 mins fire resistance from single layer partitions up to 10m high. Class '0' certification. European class A2. | <br><b>Rigid Structure</b><br>Category 1 racking resistance provided by 12.5mm Fermacell.    |
| <br><b>Moisture Resistant</b><br>Suitable for humid areas.  | <br><b>Rapid Finishing</b><br>FST (Fine Surface Treatment) eliminates plastering trades.     |

**Modern construction needs modern materials.**

Design innovation combined with increasing pressure from Building Regulations means that materials must save time and money on site and offer technically superior solutions.

Fermacell is one such material. A high performance multi-purpose building board that when installed combines the properties of solid blockwork with the speed and flexibility of conventional drywall techniques, letting designers use radical solutions in internal space planning.

**COMPOSITION**

Fermacell is produced using ordinary materials in an extraordinary way. Recycled gypsum, recycled cellulose fibres from post consumer waste paper and recycled water are combined to form a homogenous mass, which is then formed into a dense sheet material. After drying, the large format boards are cut to size.

The manufacturing technique is not only unique because of the material it produces, but also due to the fact that the process itself is fully recycling – all by-products are fed back into the system, ensuring no waste is produced. Both the product and the process have been awarded the coveted Rosenheim Institute of Construction Biology and Ecology certificate.

Fermacell boards are third party accredited by BBA, ETA and the ECO Institute.



## GENERAL PROPERTIES AND APPLICATIONS

There are a vast array of construction systems and techniques to consider when specifying internal finishes.



For partitions, this is most apparent when the properties required of the finished wall call for more than one type of building board to be used in the construction. Hotel bathrooms, for example, often require Moisture Resistance with Acoustic Insulation and Fire Protection. Hospitals will add Impact Resistance and flexibility in accepting wall mounted fittings to this. These criteria almost always demand compromise solutions involving specialist board selection and composite layers, often with costly and time consuming consequences. This in turn creates the potential for confusion, both at detailed drawing stage and on site. Additionally, multiple layering inevitably means thicker walls.

Fermacell offers a unique, single point solution to these problems, combining high levels of Fire Resistance, Acoustic Insulation and Impact Strength with exceptional Screw Holding ability and inherent Moisture Resistance.

From Commercial Projects through to DIY, Fermacell can reap rewards. Fermacell requires minimal additional work prior to painting and decorating. Wallpapers and tiles can be applied direct to the board, and plaster smooth finishes, which are ready to paint in about 45 minutes can be achieved by non-skilled trades using our FST (Fine Surface Treatment) system.

The end result is a finished partition that combines the properties associated with solid masonry with the flexibility of drywall, in a construction that is often thinner, quicker and cheaper to install than both. Using a multi-purpose board that eliminates unnecessary wet trades makes practical, technical and commercial sense.

| FEATURES & BENEFITS                               |  |  |
|---|--|--|
| Feature   | Advantage  | Benefit  |
| Manufactured from Recycled Materials              | No paper wrap and fully recyclable                               | Sustainability   |
| Cellulose Fibre Reinforcement from Recycled Paper | Provides impact resistance for high traffic areas                | Increased strength                                       |
| Severe Duty Rating (Single layer of 12.5mm)       | High impact resistance   | Increased durability and decreased partition thicknesses |
| Slimmer Party Wall Solutions                      | Easier to achieve acoustic ratings                               | Potential time & cost saving                             |
| Moisture Resistant                                | Can be installed before envelope complete                        | Potential cost saving                                    |
| F60 from a Single Layer, Class 0 Certified        | Less sheets required to achieve desired fire resistance          | Potential cost saving                                    |
| Holds 30kg on a Screw, 50Kg with Toggle Bolt      | Minimal service ply/partess or noggings required                 | Potential cost saving                                    |
| Multi Purpose Board                               | Results in rationalisation of boards                             | Saving through quality control                           |
| Ecologically Certified                            | Important contribution to overall health & wellbeing             | Comfort  |
| Easily applied Fine Surface Treatment (FST)       | No need for plastering trades or water ingress into the building | Time and co-ordination savings                           |

| LOAD-CARRYING CAPACITY OF Fermacell WALLS               |   |   |   |    |
|---|---|---|---|----|
| Fermacell Gypsum Fibreboards (thickness) <sup>(1)</sup> | Loadbearing strength in kg <sup>(2)</sup><br>NB: Factor of safety 2                 |   |   |    |
|   | Picture hooks fixed by nails  | Screw with cont. thread 5mm dia. <sup>(3)</sup>                                       | Toggle Bolt/ Cavity Fixing <sup>(4)</sup>   |    |
|   |  |  |  |    |
| 10mm  | 15  | 25  | 20  | 40 |
| 12.5mm  | 17  | 27  | 30  | 50 |
| 12.5 + 10mm   | 20  | 30  | 35  | 60 |
| 15mm  | 18  | 28  | 30  | 55 |
| 18mm  | 20  | 30  | 35  | 60 |

- (1) Maximum stud centres = 50 x board thickness.  
N.B. Where fixings are less than 500mm apart, reduce the load per fixing by 50%. If a stud support separates the fixings, then use the full loadbearing strength shown above.
- (2) Safety factor: 2 (Static load with relative humidity of up to 85%).
- (3) Depth of cupboard or shelves: max. 350mm.
- (4) Standard toggle bolt with > 4mm dia. screw.  
(The toggle bolt manufacturer's instruction should be followed.)

## Fermacell is available in standard sizes as well as custom formats up to 6000mm x 2540mm.

Wallboard thicknesses range from 10mm to 18mm. This choice gives both specifier and installer the ability to select the most appropriate product to speed installation and eliminate waste.

### ONE-MAN BOARD

One-man boards are available in 1200 x 800, 1200 x 1200 and 1500 x 1000mm.

### STANDARD SIZE BOARDS

Standard size boards in thicknesses from 10mm to 18mm are available. Special sizes to eliminate waste and reduce jointing are available to order.

### TAPERED EDGE BOARDS

Tapered edge boards are available with 2 or 4 sided Tapered edges for conventional Dry Lining installation techniques.

### POWERPANEL H<sub>2</sub>O BOARDS

Powerpanel H<sub>2</sub>O is a cement bonded light-concrete board with a laminated structure, reinforced both sides with an alkali-resistance glass fibre mesh. H<sub>2</sub>O is a water resistant board for wet areas and semi exposed applications.

### FLOORING SYSTEMS

Fermacell Flooring Systems are a dry alternative to conventional wet screed systems and are designed for upgrading both impact and airborne sound insulation in floors, or for increasing thermal performance. They are also particularly suitable for use with warm water underfloor heating systems and can be used for upgrading the fire protection to the upper surface of a floor construction.

### MODULAR BUILDING

For factory based modular construction and timber frame housing applications, boards up to 6000 x 2540mm can be supplied reducing the need of jointing.

### SHEATHING BOARD

Fermacell Gypsum Fibreboard has been tested independently for use as a sheathing board in vented and insulated rainscreen applications.

The boards should be covered with a protective membrane at the earliest opportunity, ensuring they are not left exposed for more than 7 days. In extreme conditions, cover boards as soon as possible.

Test in accordance with CWCT Standard Test Methods at a UKAS accredited facility.

### ACCESSORIES

A full range of accessories is available including Fermacell Screws, Jointstik, Joint Filler and Fine Surface Treatment ensuring perfect results whatever the applications.

### STEEL PROFILES

Metal studs, tracks and reinforcement steel profiles specifically developed and tested for fermacell boards, offering a complete system solution for demanding specifications.



## FERMACELL BOARD DATA

| DATA, NOMINAL VALUES  |                            |
|---|----------------------------|
| Dimensional tolerances at constant humidity – Board dimensions  |                            |
| Length  | + 0 / -2mm                 |
| Width   | + 0 / -2mm                 |
| Diagonal difference   | ≤ 2mm                      |
| Thickness: 10 / 12.5 / 15 / 18  | ± 0.2mm                    |
| Nominal density, strength   |                            |
| Nominal density (production target)   | 1150 ± 50kg/m <sup>3</sup> |
| Bending strength (after drying at 40°C), at right angles to the board surface   | ≥ 5.8 N/mm <sup>2</sup>    |
| Transverse strength   | ≥ 0.3 N/mm <sup>2</sup>    |
| Certified tensile values according to DIN 1052 (Permit No: Z-9.1-434)   |                            |
| Bending perpendicular to the board surface  | 1.2 N/mm <sup>2</sup>      |
| Bending in board surface  | 1.1 N/mm <sup>2</sup>      |
| Tension in board surface  | 0.5 N/mm <sup>2</sup>      |
| Pressure in board surface   | 2.0 N/mm <sup>2</sup>      |
| Pressure perpendicular to the board surface   | 2.5 N/mm <sup>2</sup>      |
| Shearing in board surface   | 0.3 N/mm <sup>2</sup>      |
| Shearing perpendicular to the board surface   | 0.6 N/mm <sup>2</sup>      |
| Modulus calculations (Permit No. Z-9.1-434)   |                            |
| E-Modulus perpendicular to the board surface  | 3800 N/mm <sup>2</sup>     |
| E-Modulus parallel to the board surface   | 3800 N/mm <sup>2</sup>     |
| E-Modulus tension   | 3800 N/mm <sup>2</sup>     |
| E-Modulus compression   | 3800 N/mm <sup>2</sup>     |
| Shearing modulus G perpendicular to the board surface   | 1600 N/mm <sup>2</sup>     |
| Shearing modulus G bending in the board surface   | 1600 N/mm <sup>2</sup>     |
| Additional data   |                            |
| Vapour Diffusion Resistance EN ISO 12572 μ  | 13                         |
| Thermal conductivity λ  | 0.32 W/mK                  |
| Specific heat capacity c  | 1.1 kJ/kgK                 |
| Brinell hardness  | 30 N/mm <sup>2</sup>       |
| Swelling after 24 hrs saturation  | < 2%                       |
| Thermal co-efficient of expansion   | 0.001%/K                   |
| Expansion/shrinkage on alteration of the relative humidity of 30% (20°C)  | 0.25mm/m                   |
| Moisture content at 65% relative air humidity and 20°C air temperature  | 1.3%                       |
| Construction material category according EN 13501-1   | A2-s1, d0                  |
| pH value  | 7-8                        |
| Characteristic strength and stiffness values of Fermacell Gypsum Fibreboard in N/mm <sup>2</sup> for design calculation according to EN 1995-1-1 and WN 1993-1-1 - See ETA document | Thickness of board in mm   |
|   | 10   12.5   15   18        |
| Perpendicular to the plane of the board   |                            |
| Bending f <sub>m,k</sub>  | 4.6   4.3   4.0   3.6      |
| Shear f <sub>v,k</sub>  | 1.9   1.8   1.7   1.6      |
| In plane of the board   |                            |
| Bending f <sub>m,k</sub>  | 4.3   4.2   4.1   4.0      |
| Tension f <sub>t,k</sub>  | 2.5   2.4   2.4   2.3      |
| Compression f <sub>c,k</sub>  | 8.5   8.5   8.5   8.5      |
| Shear f <sub>v,k</sub>  | 3.7   3.6   3.5   3.4      |

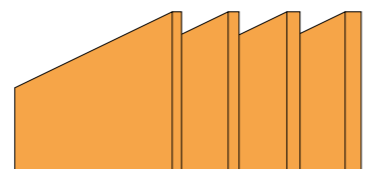
| BOARDS   |      |      |    |    |
|--|------|------|----|----|
| Sizes (mm)   | 10   | 12.5 | 15 | 18 |
| Weight per m <sup>2</sup> (kg)   | 11.5 | 15   | 18 | 21 |
|  |      |      |    |    |
| Square edge boards   |      |      |    |    |
| 1500 x 1000mm  | •    | •    | •  | •  |
| 1200 x 1200mm  | •    | •    | •  | •  |
| 2400 x 1200mm  | •    | •    | •  | •  |
| 2700 x 1200mm  | •    | •    | •  | •  |
| 3000 x 1200mm  | •    | •    | •  | •  |
| Tapered edge boards  |      |      |    |    |
| 1200 x 800mm (4 s.)  | •    | •    | •  | •  |
| 2400 x 1200mm (4 s.)   | •    | •    | •  | •  |
| 2400 x 1200mm (2 s.)   | •    | •    | •  | •  |
| Specially cut sizes on request   |      |      |    |    |

**FERMACELL CORRESPONDS TO TYPE GF-W2 AND GF-1 TO EN 15283-12**

**12.5MM FERMACELL GIVES CATEGORY 1 RACKING RESISTANCE, ELIMINATING THE NEED FOR A PLYWOOD AND A PLASTERBOARD.**

**FERMACELL NOW HAS A RANGE OF CHARACTERISTIC VALUES FOR REDUCED CENTRE FIXINGS. PLEASE CALL OUR TECHNICAL DEPARTMENT FOR FURTHER INFORMATION.**

## TRAINING

Fermacell is an innovative, high performance product and installation techniques, whilst not difficult, are different to standard Dry Lining practice. For this reason we recommend that first time users of Fermacell – either specifiers or installers – contact us for a brief explanation of the main differences in the use of the board. Although this can be usually accomplished by telephone, we always encourage training. On site training can be arranged by contacting one of our Sales Managers.

## CPD

RIBA approved CPD accredited presentations on the features, benefits and use of Gypsum Fibreboards can be arranged at short notice. These presentations are free and are available to professional and trade bodies, architectural and other building practices as well as schools of architecture and building colleges.

## INTERNATIONAL CERTIFICATION

Fermacell is produced to the highest international quality standards. In addition to the accreditation of our factories to ISO 9001 and ISO 14001 to ensure consistent product quality, Fermacell itself has been certified by various leading authorities, as well as international equivalent bodies throughout Europe.

## RESEARCH LED R&D

Increasing innovation in building techniques, changes in Building Regulations and requests and suggestions from our customers lead us to develop both new products and methods of application.

Our purpose built R&D centre in the Harz Mountains in Germany has a continuous programme of New Product Development.

**Our technical support staff are fully qualified to provide detailed technical solutions – usually at the time of your enquiry.**

Where special detailing or a non-standard solution is required we shall undertake to have given a preliminary answer within 48 hours.

Visits either to your premises or site may be arranged according to your requirements. Please call us for further assistance.

Fermacell's daily and continued use in thousands of high profile projects worldwide is a testament not only to the product's huge appeal and breadth of application, but also to the service and professionalism of our staff in supporting its users. Call our Technical Department to experience the benefits of Fermacell for yourself **+44 (0) 121 311 3480**.



Fire

Acoustics

Impact

Moisture

Environmental

Product Use

Health & Safety

Performance Criteria

**All materials used in construction in England and Wales must meet “reaction to fire” and “fire resistance” performance criteria.**

The “reaction to fire” regulations deal with the potential contribution to a fire that basic materials may make and carry the award of a Class 0 Materials of Limited Combustibility classification covering ignitability, fire propagation as well as Class 1 surface spread of flame.

Fermacell Gypsum Fibreboards carry this Class 0 classification together with Euroclass A2, the second highest performance level under new EU rules of appropriately tested gypsum wallboards. Fermacell also carries a class 1 surface spread of flame certification, the highest achievable.

The “fire resistance” performance criteria deal with the duration that a complete construction can delay the collapse of a building that is burning, or even how long it can prevent a fire from spreading from one room or one property to another. The effectiveness of the construction is measured in the number of minutes achieved in a variety of British Standard tests.

These tests have become more stringent with the introduction of new EU fire resistance tests – the BS EN 1363 series – which will use plate thermocouples to give a slower reaction to rises in temperature leading to a requirement for additional heat to follow what is nominally the same time/temperature curve as specified in BS 476.

Fermacell have solutions for loadbearing and non-loadbearing constructions, as well as K ratings and assessments for non-standard details. Please contact the Fermacell Technical Helpline for further information.



**What is acoustics?**

**The term “acoustics” embraces all aspects of sound: its generation, spread, reduction and reception in the spoken word, music and all other forms of audio.**

Airborne sources of sound, generated in the air by a vibrating object, include:

- the human voice
- radio and television
- loudspeakers
- musical instruments
- machinery

Unwanted or intrusive sound is normally referred to as “noise”.



**WHAT ARE DECIBELS?**

Sound is measured by comparing the pressure wave it creates as it travels from its source with the nominal threshold of hearing pressure and then compressing the range using a logarithmic scale.

The result is the decibel scale, which starts at 0 dB – the point at which humans begin to hear sound – and progresses to 140 dB, the point at which a single short noise is likely to irreparably damage hearing. The scale enables sound levels picked up by the ear to be easily and meaningfully analysed – even a 3 dB change in sound pressure level is considered significant.

**WHAT IS SOUND FREQUENCY?**

The vibrations that produce individual sounds are measured in cycles per second and written in hertz (Hz) units which are termed the “frequency”. The human ear, which picks up sound from 20 Hz to 20,000 Hz, has varying sensitivities to different frequencies although the optimum range is between 1,000 Hz to 4,000 Hz.

**WHAT IS PITCH?**

Pitch is another term for frequency.

| EFFECTS OF SOUND REDUCTION VALUES ON AUDIBILITY |  |
|---|--|
| R <sub>w</sub>                                  | Noise level  |
| 30 dB   | Normal conversation can be distinguished   |
| 35 dB   | Loud conversation can be distinguished   |
| 40 dB   | Loud conversation can be heard but not distinguished                             |
| 45 dB   | Loud conversation can be heard   |
| 50 dB   | Shouting can be heard but not distinguished                                      |
| 55 dB   | Speech is totally unheard with a high level of privacy from other domestic noise |
| 60 dB   | High level of privacy including noise from Hi-fi and television                  |

Fire

Acoustics

Impact

Moisture

Environmental

Product Use

Health & Safety

An Introduction to Sound

THE THEORY OF SOUND INSULATION

Airborne sound insulation is the ability of material separating two rooms to minimise the passage of airborne sound through either the dividing element or its surrounding structure. The materials are assessed on a sound reduction index by relating the sound power reduction through the material itself.

Purpose built laboratories consist of two rooms with an opening between them, into which a test sample is inserted, thus allowing an evaluation of partitioning and other insulation structures.

Similarly, testing on site also involves establishing the values relating to the sound pressure level reductions between two rooms. Then reverberation time of the receiving room indicates the Standardised Level Difference ( $D_{nT}$ ).

While a graph of sound insulation vs. frequency may be plotted from one third octave band measurements between 100 Hz and 5,000 Hz, a simplified rating method has been drawn up. By overlaying the measured sound insulation graph with a standard curve shape on which the position may be altered to meet certain criteria, a single figure may be calculated from the sound insulation spectrum. This single figure, when achieved in lab tests, is the Weighted Sound Reduction Index ( $R_w$ ) and is called the Weighted Standardised Level Difference ( $D_{nT,w}$ ) following site tests.

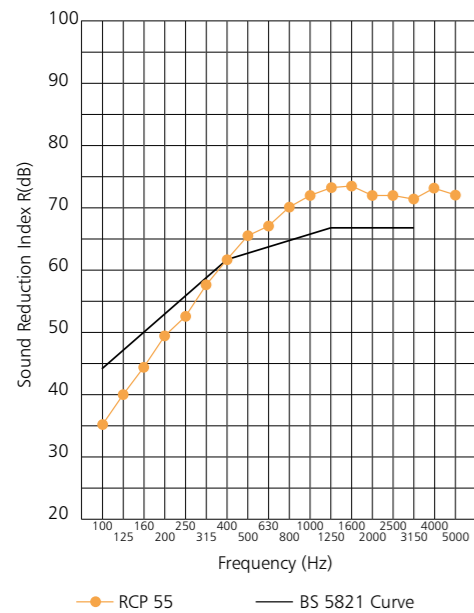

IMPACT SOUND

Impact sound, essentially vibration caused by the collision of one object with another, usually footsteps, applies only to floors.

Testing of impact sound insulation involves dropping, in turn, five similar hammer heads that comprise a standard tapping machine onto a floor at a rate of ten impacts per second. The resultant impact sound is measured in the room below in terms of sound pressure levels.

The use of a resilient layer during testing is not allowed.

SOUND INSULATION DESIGN

By plotting surface mass against "mean" sound insulation, it has been demonstrated by The Empirical Mass Law that the insulation increases by 4 dB to 5 dB with every doubling of the surface mass.

This has led to the development of a series of practical and economical methods of sound insulation. They include:

- The use of a single light gauge metal stud frame, lined with a layer of board, to produce separation and discontinuity. Even though the air in the cavity can act as a "spring" connection between the boards, this method gives insulation **at least 5 dB greater than the empirical prediction.**
- The use of glass wool or rock wool infill to effectively dampen the air spring in the cavity to produce a **5 dB improvement to the value.**
- Double layers of wallboard operating as semi independent linings and producing up to **10 dB improvements.**
- Creation of virtually independent linings by fixing a resilient bar to one side of the metal stud frame for **6 dB improvement.**
- It is possible to optimise airsprung discontinuity and produce good low frequency improvements by incorporating twin independent frames that increase wall width as well as provide structural discontinuity. Acoustic cross braces optimise the maximum partition heights achievable.

The Approved Document E is guidance to acoustic performance standards for houses, flats, schools, hotels and hostel types of accommodation.

Whether new build or material change of use, all projects have different criteria, to improve the sound insulation and privacy between domestic and residential rooms.

There are several ways of approaching compliance, primarily with the design of separating walls and floors that will meet and exceed the requirements in the guidance document. The onus is then on the installer to ensure good on site workmanship and consideration to the prevention of flanking transmission around the installed systems. As Part E sets out a requirement for 10% pre-completion site testing of separating (party) walls and floors, builders will need to prove, by site testing, that the sound insulation meets the requirements of the new regulations.

Acoustic failure will prove costly.

New build dwellings are exempt if built with approved Robust Details (RDs), however sample testing is still carried out.

PART E AT A GLANCE

E1 The regulations to protect against sound from other parts of a building or adjoining buildings apply to dwelling houses, flats and "rooms for residential purposes" in hotels, hostels, boarding houses, halls of residence and care homes and call for pre-completion testing.

E2 Internal walls and floors between bedrooms, WCs and other rooms are required to meet a specific laboratory test standard of airborne sound insulation of 40 dB  $R_w$  or by minimum mass calculations depending on construction. There is no requirement for pre-completion site testing.

E3 Common internal areas of buildings containing flats or rooms for residential purposes must be designed to prevent more reverberation than is reasonable.

E4 Acoustic insulation guidelines for schools – which require control of sound insulation, reverberation and indoor ambient noise levels are contained in Building Bulletin 93.

SCOTLAND AND IRELAND

Fermacell can also provide solutions in relation to Scottish, Northern Irish and Irish building regulation requirements.

### SOUND INSULATION IN DWELLINGS

#### SEPARATING WALLS, FLOORS AND STAIRS

The airborne sound insulation standard for separating walls, floors and stairs in purpose built dwelling houses and flats is 45 dB, expressed as  $D_{nT,w} + C_{tr}$ . This target, with the addition of the  $C_{tr}$  correction factor, will ensure substantial sound insulation. Floors and stairs should have maximum values of impact sound insulation of 62 dB  $L_{nT,w}$ .

The figures for dwellings and flats formed by material change of use are 43 dB and 64 dB respectively.

Walls in purpose built rooms for residential purposes carry a standard for airborne sound insulation of 43 dB  $D_{nT,w} + C_{tr}$  floors and stairs require 45 dB  $D_{nT,w} + C_{tr}$  and 64 dB  $L_{nT,w}$  impact sound requirements.

#### INTERNAL WALLS AND FLOORS

Laboratory values for all categories of internal walls are 40 dB  $R_w$  in both wall and floor calculations. There is no requirement for pre-completion testing under the legislation.

### PART E AND RD SOLUTIONS

Fermacell Gypsum Fibreboard totally satisfies the requirements of Part E. It must be remembered that pre-completion tests must be carried out on site by an accredited third party test body on 10% of all different types of new dwellings.

An alternative to pre-completion testing is the approval of separating (party) walls and floors for new builds only, as Robust Details (RDs). They will be deemed to satisfy Part E if they are built correctly.

RD solutions used in projects other than new build will, however, be subject to pre-completion testing.

### SOUND INSULATION IN SCHOOLS

Building Bulletin 93 associated with Document E deals specifically with acoustics in new school buildings, covering airborne insulation between teaching and learning spaces, and impact sound insulation of their floors. It does not cover administration and ancillary areas.

The table below shows the performance requirements for airborne sound insulation between rooms expressed in  $D_{nT}(tmf,max)_w$  and impact sound insulation of floors maximum weighted BB93 standardised impact sound pressure level  $L_{nT}(tmf,max)_w$ .

| AIRBORNE SOUND INSULATION BETWEEN ROOMS   |                   |                    |                               |                               |                 |   |                              |                             |         |                    |              |                       |               |           |             |                               |                                   |
|---|-------------------|--------------------|-------------------------------|-------------------------------|-----------------|---|------------------------------|-----------------------------|---------|--------------------|--------------|-----------------------|---------------|-----------|-------------|-------------------------------|-----------------------------------|
|   | Nursery play room | Nursery quiet room | Primary / secondary classroom | Open plan teaching / resource | Music classroom | Music performance room / recording studio | Lecture room (fewer than 50) | Lecture room (more than 50) | Library | Science laboratory | Drama studio | Metal / woodwork room | Assembly hall | Gymnasium | Dining room | Offices / toilets / corridors | Impact sound insulation of floors |
| Nursery play room                         | 55                |                    |                               |                               |                 |   |                              |                             |         |                    |              |                       |               |           |             |                               | 65                                |
| Nursery quiet room                        | 55                | 40                 |                               |                               |                 |   |                              |                             |         |                    |              |                       |               |           |             |                               | 60                                |
| Primary / secondary classroom             | 55                | 45                 | 45                            |                               |                 |   |                              |                             |         |                    |              |                       |               |           |             |                               | 60                                |
| Open plan teaching / resource             | 50                | 45                 | 45                            | 40                            |                 |   |                              |                             |         |                    |              |                       |               |           |             |                               | 60                                |
| Music classroom                           | 55                | 55                 | 55                            | 55                            | 55              |   |                              |                             |         |                    |              |                       |               |           |             |                               | 55                                |
| Music performance room / recording studio | 60                | 45                 | 55                            | 55                            | 60              | 60  |                              |                             |         |                    |              |                       |               |           |             |                               | 55                                |
| Lecture room (fewer than 50)              | 55                | 45                 | 45                            | 45                            | 55              | 55  | 45                           |                             |         |                    |              |                       |               |           |             |                               | 60                                |
| Lecture room (more than 50)               | 55                | 45                 | 50                            | 50                            | 60              | 60  | 50                           | 50                          |         |                    |              |                       |               |           |             |                               | 55                                |
| Library                                   | 55                | 40                 | 45                            | 45                            | 55              | 55  | 45                           | 50                          | 45      |                    |              |                       |               |           |             |                               | 60                                |
| Science laboratory                        | 50                | 45                 | 45                            | 40                            | 55              | 55  | 45                           | 50                          | 45      | 40                 |              |                       |               |           |             |                               | 65                                |
| Drama studio                              | 55                | 55                 | 55                            | 50                            | 60              | 60  | 55                           | 55                          | 55      | 50                 | 55           |                       |               |           |             |                               | 55                                |
| Metal / woodwork room                     | 55                | 55                 | 55                            | 50                            | 55              | 55  | 55                           | 55                          | 55      | 50                 | 55           | 50                    |               |           |             |                               | 65                                |
| Assembly hall                             | 55                | 55                 | 55                            | 50                            | 55              | 55  | 55                           | 55                          | 55      | 50                 | 55           | 55                    | 55            |           |             |                               | 60                                |
| Gymnasium                                 | 55                | 55                 | 55                            | 50                            | 55              | 55  | 55                           | 55                          | 55      | 50                 | 55           | 50                    | 55            | 50        |             |                               | 65                                |
| Dining room                               | 55                | 55                 | 55                            | 50                            | 55              | 55  | 55                           | 55                          | 55      | 50                 | 55           | 50                    | 55            | 50        | 45          |                               | 65                                |
| Offices / toilets / corridors             | 55                | 55                 | 55                            | 50                            | 55              | 55  | 55                           | 55                          | 55      | 50                 | 55           | 50                    | 55            | 50        | 50          | 50                            | 65                                |



## SOUND INSULATION IN HOSPITALS

Hospitals are expected to meet acoustic design and performance criteria as set out in a number of HTM documents.

Performance requirements for airborne sound insulation set out in the table below, range from 43 dB  $R_w$  to 53 dB  $R_w$  depending on the location of the rooms within the building. Designers seeking to achieve these values should also consider the potential for eliminating or minimising flanking sound transmission (sound that might be transferred through surrounding structures, such as plant and mechanical services).

Careful selection of internal surface finishes contributes greatly to the control of reverberation which can also affect acoustic qualities.

Fire requirement in hospitals outlined in HTM81, which is based on Approved Document B of the building regulations, state that partition walls and floors between rooms must be provided with appropriate levels of fire resistance as well as acoustic insulation.

*Robust Fermacell boards meet the acoustic and fire requirements for walls and floors in hospitals, offering superior strength, resistance to impact damage and pull-out for fixings.*

PERFORMANCE REQUIREMENT FOR AIRBORNE SOUND INSULATION BETWEEN ROOMS IN dB( $R_w$ ) for HTM56

|                       | Consulting room | Examination rooms | Treatment rooms | Speech therapy rooms | Offices | Seminar rooms | Single-bed wards | Multi-bed wards | Day rooms | Nurseries | Toilets and bathrooms | Utility rooms | Ward pantries | Plant motor rooms |
|-----------------------|-----------------|-------------------|-----------------|----------------------|---------|---------------|------------------|-----------------|-----------|-----------|-----------------------|---------------|---------------|-------------------|
| Consulting room       | 43              |                   |                 |                      |         |               |                  |                 |           |           |                       |               |               |                   |
| Examination rooms     | 43              | 43                |                 |                      |         |               |                  |                 |           |           |                       |               |               |                   |
| Treatment rooms       | ●               | 53                | 43              |                      |         |               |                  |                 |           |           |                       |               |               |                   |
| Speech therapy rooms  | 48              | 48                | ●               | 48                   |         |               |                  |                 |           |           |                       |               |               |                   |
| Offices               | 43              | 43                | 53              | 48                   | 48      |               |                  |                 |           |           |                       |               |               |                   |
| Seminar rooms         | 48              | 43                | 48              | 53                   | 43      | 38            |                  |                 |           |           |                       |               |               |                   |
| Single-bed wards      | 43              | 43                | ●               | 48                   | 43      | 48            | 43               |                 |           |           |                       |               |               |                   |
| Multi-bed wards       | 53              | 53                | 48              | ●                    | 48      | 43            | 53               | 43              |           |           |                       |               |               |                   |
| Day rooms             | 53              | 53                | 43              | ●                    | 48      | 43            | 53               | 43              | 48        |           |                       |               |               |                   |
| Nurseries             | ●               | ●                 | 43              | ●                    | 53      | 48            | ●                | 48              | 43        | 43        |                       |               |               |                   |
| Toilets and bathrooms | 48              | 48                | 48              | 53                   | 43      | 43            | 48               | 48              | 48        | 48        | 43                    |               |               |                   |
| Utility rooms         | ●               | ●                 | 43              | ●                    | 53      | 48            | ●                | 48              | 43        | 43        | 48                    | 43            |               |                   |
| Ward pantries         | 48              | 48                | 48              | 53                   | 43      | 38            | 48               | 43              | 43        | 48        | 43                    | 48            | 38            |                   |
| Plant motor rooms     | ●               | ●                 | ●               | ●                    | ●       | ●             | ●                | ●               | ●         | ●         | ●                     | ●             | ●             | ●                 |

● Special construction may be necessary. Please consult Building Control for details.

Fermacell SOLUTIONS FOR WALLS

| Acoustic performance ( $R_w$ dB) | Fire resistance (minutes) | Timber frame       | Steel frame | Masonry upgrade |
|----------------------------------|---------------------------|--------------------|-------------|-----------------|
| 38                               | 30                        | 1H13               | 1S15        | 3S01            |
|                                  | 60                        | 1H22               | 1S21        | 3S21            |
|                                  | 90                        | 1H31               | 1S31        | -               |
| 43                               | 30                        | 1H23 or 1H31       | 1S15        | 3S01            |
|                                  | 60                        | 1H23 or 1H31       | 1S21        | 3S21            |
|                                  | 90                        | 1H31               | 1S31        | -               |
| 48                               | 30                        | 1H23 or 1H31       | 1S11        | 3S01            |
|                                  | 60                        | 1H23 or 1H31       | 1S21        | 3S21            |
|                                  | 90                        | 1H32 or 1H31       | 1S31        | -               |
| 53                               | 30                        | 1H32, 1H23 or 1H35 | 1S21        | 3S01            |
|                                  | 60                        | 1H32, 1H23 or 1H35 | 1S21        | 3S21            |
|                                  | 90                        | 1H32               | 1S31        | -               |

HTM08-01 has recently been introduced and offers simpler guidance on performance of partitions within Hospitals. These areas include:

- (1) The performance requirements are shown as on-site figures.
- (2) Guidance is given on designing from Laboratory ( $R_w$ ) performance to on-site performance ( $D_nT,w$ ). A minimum difference of 5dB should be allowed, and even up to 7dB to allow for typical services and construction details.
- (3) The effect of doors in partitions is clearly defined, allowing a more common sense approach for design.
- (4) An additional allowance must be made for the area of the separating element and the volume of the room.
- (5) Fermacell systems can provide simple solutions for all these criteria, Tables 3, 4, 5 and appendix a should be referenced for design.

### Duty Rating & Impact Performance – Tested to BS 5234-2:1992.

The simplest Fermacell steel stud partitions have been tested to BS5234-2 and achieve a SEVERE duty rating.\*

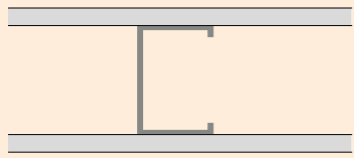

Thus specifying duty rating with Fermacell solutions is a simple process. In addition Fermacell has carried out a vast range of testing, to DIN 4103, for greater wall heights with different board configurations, stud profiles and centres. This allows Fermacell to provide a comprehensive range of rated build heights. This includes soft and hard body impact testing. A severe duty can be achieved by using a single 75mm DIN standard Fermacell stud with a single layer of 12.5mm Fermacell to one side.



\*up to 3 and 5 metres

| CERAM TEST DATA TO BS 5234:Pt2      |   |              |             |
|-------------------------------------|---|--------------|-------------|
| Test wall                           | Description   | Build height | Result      |
| Fermacell 1S15 (1)                  | Partition 4.50m long by 5.0m high with overall thickness of 100mm; comprising 1 layer each side of 12.5mm Fermacell Board fixed to 0.6mm x 75mm x 50mm Fermacell steel studs at 600mm centres                   | 3m & 5m      | Severe Duty |
| Fermacell 3S01 (2)                  | Independent Lining 4.50m long by 3.0m high with overall thickness of 100mm; comprising 1 layer one side of 12.5mm Fermacell Board fixed to 0.6mm x 75mm x 50mm Fermacell steel studs at 600mm centres           | 3m           | Severe Duty |
| Fermacell 1S15 H <sub>2</sub> O (3) | Partition 4.50m long by 3.0m high with overall thickness of 100mm; comprising 1 layer each side of 12.5mm Powerpanel H <sub>2</sub> O Board fixed to 0.6mm x 75mm x 50mm Fermacell steel studs at 600mm centres | 3m           | Heavy Duty  |

|                           |  |
|---------------------------|--|
| 1S15 (1)                  |  |
| 3S01 (2)                  |  |
| 1S15 H <sub>2</sub> O (3) |  |

### FERMACELL SOFT IMPACT TEST TO DIN 4103

The certificate for soft impact is based on an assessment of the ability of the whole partition to withstand a semi static load. A soft impact on light-weight partitions can result from, for example, the impact of a human body or in the case of panic caused by fire as a result of the crowd pressure in corridors that line an escape route.

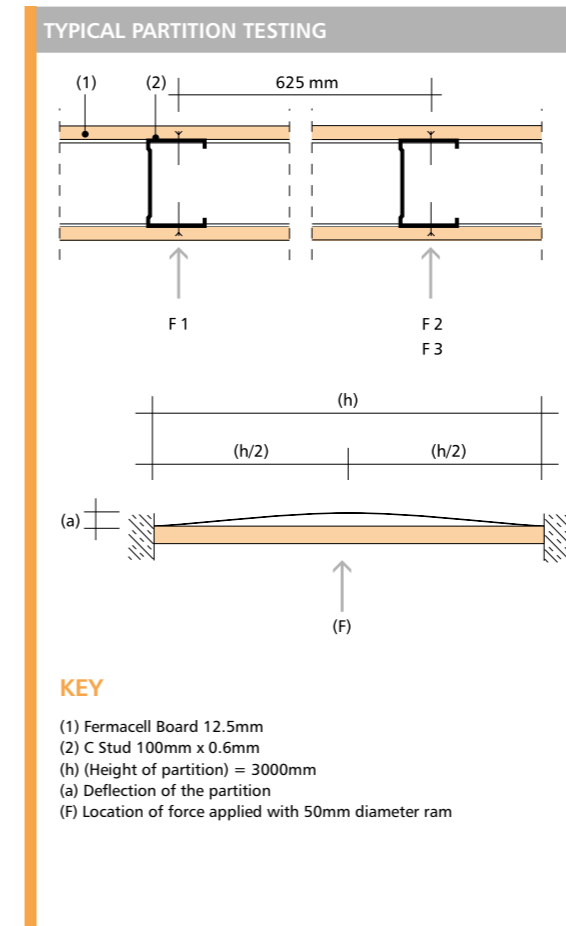

| Load type  | Force |
|--|-------|
| Soft horizontal impact                                     | kN    |
| F1 Force applied over stud to create deflection of 5mm     | 1.119 |
| F2 Force applied between studs to create deflection of 5mm | 0.605 |
| F3 Force applied between studs to break through board      | 1.505 |

### FERMACELL HARD IMPACT TEST TO DIN 4103

The resistance to hard impact is determined by a drop ball test. A steel ball 63.5mm in diameter weighing 1030g is released in free fall on to the face of a 12.5mm Fermacell Board. The drop ball tests are carried out on 1200mm wide pieces of board, spanned between two supports at 625mm. The impact points are in the middle of the board and near the edge of the board.

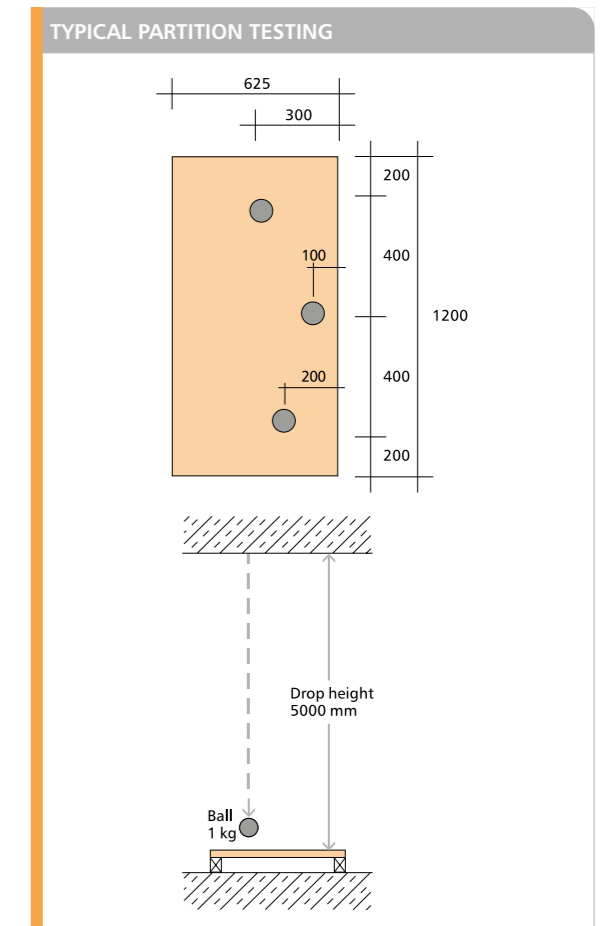

## FERMACELL FIXINGS AND LOADINGS

The flexibility of fixing to Fermacell means you can put your shelves or cupboards where you want to.

### FIXINGS TO WALLBOARDS

- Fermacell boards have a great hanging strength.
- Many items can be fixed directly to the boards without fastening to the sub-structure.
- The table below shows the loadbearing capability of a wide range of fittings.
- The loadbearing capability refers to static (dead) loads only.
- For live loads which are subject to increase (eg washbasins or stair-rails), the maximum load should be calculated and patresses of plywood added behind the wall.
- Fixing back to the existing studs will provide additional support where required.

### MAXIMUM WALL LOADING

- With single stud walls a maximum of 150kg/m is recommended.

For separated stud walls and independent wall linings, please contact the Fermacell Technical Department for further details.

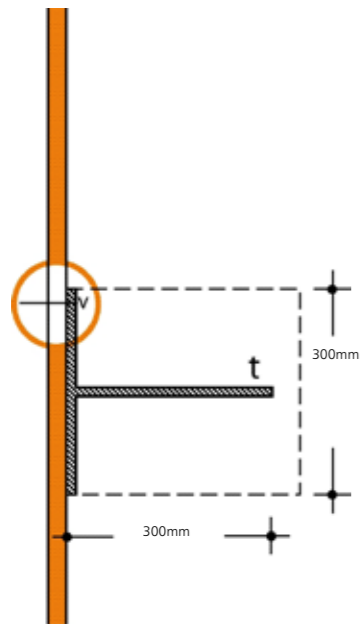

- Permissible load  $t$  applied to a cantilevered arm at distance  $t$ , using a single fixing directly into the board.

| Fermacell Gypsum Fibreboards (thickness) <sup>(1)</sup> | LOAD-CARRYING CAPACITY OF Fermacell WALLS                           |   |                            |    |
|---|---|---|----------------------------|----|
|   | Loadbearing strength in kg <sup>(2)</sup><br>NB: Safety factor of 2 |   |                            |    |
|   | Picture hooks fixed by nails  | Screw with cont. thread 5mm dia. <sup>(3)</sup> | Toggle Bolt <sup>(4)</sup> |    |
|   |   |   |                            |    |
| 10mm  | 15  | 25  | 20                         | 40 |
| 12.5mm  | 17  | 27  | 30                         | 50 |
| 12.5 + 10mm   | 20  | 30  | 35                         | 60 |
| 15mm  | 18  | 28  | 30                         | 55 |
| 18mm  | 20  | 30  | 35                         | 60 |
| 12.5mm H <sub>2</sub> O                                 | N/A   | N/A   | N/A                        | 40 |
| 2 x 12.5mm H <sub>2</sub> O                             | N/A   | N/A   | N/A                        | 50 |

(1) Maximum stud centres = 50 x board thickness.  
N.B. Where fixings are less than 500mm apart, reduce the load per fixing by 50%. If a stud support separates the fixings, then use the full loadbearing strength shown above.  
(2) Safety factor: 2 (Static load with relative humidity of up to 85%).  
(3) Depth of cupboard or shelves: max. 350mm.  
(4) Standard toggle bolt with > 4mm dia. screw.  
(The toggle bolt manufacturer's instruction should be observed.)

The stated load values can be added up, if the fixing centres are  $\geq$  500mm. For lesser fixing centres, 50% of the relevant permissible load per fixing should be used. The total single loads for walls should not exceed 1.5 kN/m and for free-standing Dry Lining and double studwalls not physically connected to one another, 0.4 kN/m. The stability of the wall or casing should be verified as described above according to DIN 4103 Part 1 and BS 5234.

### MAXIMUM TILE WEIGHTS

- The maximum recommended tiles weight is:
  - Fermacell Gypsum Fibreboards - 35kg/m<sup>2</sup>
  - Fermacell Powerpanel H<sub>2</sub>O - 50kg/m<sup>2</sup>
 \*Reduce stud centres as required, dependant on tile substrate requirements.
- For any weight greater than that please contact our Technical Department on **+44 (0) 121 311 3480** for more details.

## The moisture resistance qualities of Fermacell boards have been confirmed by a series of the most uncompromising tests developed specifically for rainscreen evaluation.\*

Simulated cascading rain, 600 kpa wind speeds and intense humidity, far in excess of normal weather conditions that would hit a building in its entire lifetime, have demonstrated that the 12.5mm Fermacell as a backerboard product is ideal for external use.

It may be applied as a sheathing board on both timber frames and structural steel framed external wall infill panels, used as a liner for unexposed canopies and also for lining roof trusses used as separating wall frames.



Fermacell gypsum fibreboard is moisture resistant and can be used in semi exposed applications. Fermacell also offers a good degree of mould resistance.

As well as a sheathing board, Fermacell Gypsum Fibreboards provide outstanding performance as a tile backing board in environments with frequent exposure to water and moisture – up to 80% humidity and it is the ideal solution for:

- Kitchens
- Laundries
- Bathrooms
- Shower Cubicles
- Plant Rooms

Furthermore, fermacell board can make a significant contribution to improved BREEAM ratings of new and refurbished commercial and residential buildings.

The moisture resistance qualities of Fermacell are accompanied by a host of additional advantages including: substantial financial benefits (Fermacell can save up to 50% per m<sup>2</sup> when compared to other boards); its excellent fire and acoustic properties; its ease of fixing, cutting, jointing and general handling; and considerably less remedial problems.

The ability of Fermacell to withstand a degree of moisture lends it to reducing project time and glitches on site, where inclement weather can really slow things down. Spandrel Panels, prefabricated with Fermacell, are already fitted into roof spaces where limited weather protection is in place. We would always recommend that our advice is sought in these matters first as Fermacell is moisture resistant, not waterproof.

All these benefits are accompanied by Fermacell's commitment to a totally environmentally friendly product manufactured from recyclable materials which therefore makes Fermacell itself also completely recyclable.

\*The tests were conducted in accordance with guidelines set down by the Centre for Windows and Cladding Technology and included air permeability, static and dynamic watertightness, and wind resistance from both serviceability and safety points of view.

**Fermacell, the high performance Dry Lining board with Class 0 fire rating, excellent acoustic qualities and superb resistance to impact and moisture, brings the highest levels of environmental care and sustainability to the construction industry.**

Fermacell's unique manufacturing technique produces board of quality, flexibility and strength completely from recycled materials, making it a sustainable product that is ideal for walls, ceilings or floors.



At a state-of-the-art production facility in Holland, gypsum, a waste product from a nearby power station, and cellulose fibres from recycled paper and magazines collected throughout the Netherlands are mixed with recycled water in an 80%-20% ratio to produce homogenous sheet materials that are cured and cut to size.

All by products are fed back into the production cycle and Fermacell have even instigated a scheme for the collection and recycling of off cuts and waste created on construction sites, giving customers the opportunity to enhance their environmental reputations by demonstrating social responsibility through reduced demand for land fill.

Since its introduction to the U.K. in 1971, Fermacell, one of the brands of world-wide building materials group Xella International, has developed a fine reputation for effective solutions that meet today's challenging building and sustainability requirements.

The product, and its manufacturing process, have been awarded the coveted Rosenheim Institute of Construction Biology and Ecology Certificate and the Low Emissions Product Eco Certificate. In addition Fermacell itself has been defined as a "healthy living building material" for allergy-free environments.

#### CERTIFICATION

- BBA certificate No 90/2439
- DN EN ISO : 14001
- Recycled content to ISO 14021: newspaper and gypsum recovered from desulphurisation plants
- ETA – 03/0050
- EWC – European Waste Catalogue Ref listing REF – NO 1708 02
- Life expectancy = life of the building
- Environmental certification: Rosenheim Institute Ecology Certificate
- eco INSTITUT – Quality Assurance
- Greenspec – Material Details
- GreenGuide –
  - England
  - Wales
  - Scotland



**Fermacell's unique range of DIN standard steel studs, head and base track and reinforcement profiles are manufactured to meet the most demanding designs and building regulations.**

Fermacell steel profiles are specifically designed and manufactured to work with fermacell boards. The studs have a 50mm fixing face, made in 0.6mm thick and come in a wide range of widths and lengths. Our range of acoustic foam strips are designed to isolate the track or stud from the substrate hence reducing the possibility of flanking transmission through the frame. The acoustic foams strips are self adhesive and can be easily applied on site.



#### Stud Profiles

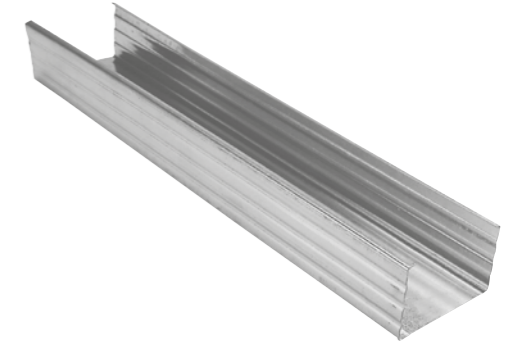

#### Head & Base Track

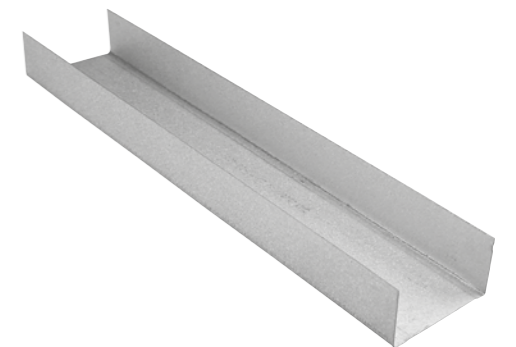

#### Door Reinforcement

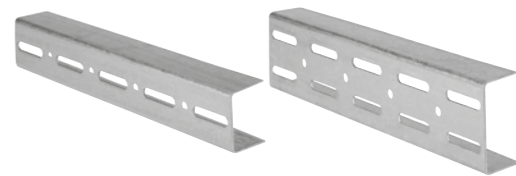

#### Accessories



Health & Safety | Product Use | Environmental | Moisture | Impact | Acoustics | Fire

Environmental Credentials

Prisons, Hospitals, Schools, Retail and Galleries

Health & Safety | Product Use | Environmental | Moisture | Impact | Acoustics | Fire

Different construction projects naturally have different partitioning requirements, but it is often the case that no matter what the final use of a building, there are common partitioning needs.

Acoustic, Fire, Impact Performance and Environmental considerations are at the top of the list of partitioning priorities: whether it is an educational or hospital establishment; retail store; sport or recreational centre or residential development, partitioning with a demonstrable pedigree such as Fermacell is no longer an option, it is essential.

Architects, main contractors and installers also have a second common goal: an installation method that is fast, and easy to schedule into the fitting out programme. Fermacell can help in both those benefits, as well as the unique FST finishing system which ensures a quality finish that eliminates the wet trades such as plastering.

**EDUCATION AND HEALTHCARE**

The Education and Healthcare construction sectors are alike in many ways and have similar needs when specifying internal partitions, linings and ceilings. The careful selection of the systems used in these public buildings is vital as they have to perform at the highest level in demanding environments. Particular attention has to be paid to the 'whole life costs' of the products used during the construction as the cost of maintenance of the building has to be managed from strict budgets.

Fermacell Gypsum Fibreboards provide significant benefits and often exceed the requirements in relation to durability and low life costs with such projects. Due to the composition of Fermacell boards our systems give the Architect, Main Contractor and Client peace of mind as they have the ability to withstand the everyday knocks and impacts that the partitions in these sectors receive everyday.

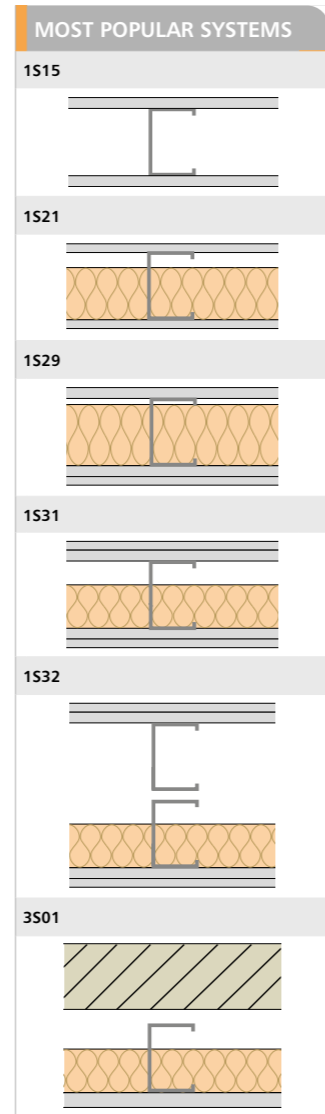

For individual system performance please refer to the Partition performance tables starting on page 38.

**RESIDENTIAL**

The single board solution with fewer layers and less insulation than plasterboard is one of the many attractions that Fermacell holds for the house builder, particularly those operating in the high end of the market and self builders seeking the best for their property. The Fermacell package of superior acoustic performance, strength, speed, quality, ease of finish, and moisture resistance have made it a firm favourite in this market – and even more so with builders of timber frame properties seeking a strong breathing wall construction that eliminates the need for plywood as a racking board at the same time.

**PRISONS AND DETENTION CENTRES**

There is no environment more demanding than the HM Prison and Magistrates Court facilities. Fermacell provides an accepted solution with a range of historical and current projects throughout England, Wales & Scotland. Drawing on this expertise Fermacell can provide tailored design and accepted systems to suit all requirements demanded by Home Office or HM Prison Services.

Fermacell boards have very high load carrying capabilities which means that the amount of reinforcement within the partition can be drastically reduced, saving cost and on site installation time. Due to the strength of Fermacell, high performance partitions with high fire protection and excellent acoustic performance can be achieved with a narrow width partition which means that the overall footprint of the partitions can be significantly reduced saving space and optimising room space.

All Fermacell boards are tested during rigorous performance tests by third party test establishments, listed here are the most commonly specified Fermacell systems in the Education and Healthcare sector.

**RETAIL**

Loadbearing comes high on the list of essentials in retail developments, although an ability to cope with impact is equally as important. An enviable loadbearing performance enables retailers using Fermacell to install most of the fixtures and fittings directly to the Fermacell Board reducing the amount of reinforcement.

**SPORTS, RECREATION AND THE ARTS**

The smooth finish of Fermacell, enhanced by the use of Fine Surface Treatment, is ideal for arts and cultural centres where large, heavy pictures and paintings are hung and regularly rehung in a quality environment.

These needs for strong partitioning are accompanied by a requirement for high impact resistance, but probably not quite as high as sports and recreation centres where hard ball sports and hefty human impact resistance is paramount. Not only does Fermacell meet all these criteria – it can be supplied in standard size sheets up to 3m high (special longer boards available) making it ideal for installations of this type.

Note: For further design guidance please refer to:

'Designing Galleries: the complete guide to developing & designing spaces & services for temporary exhibitions' Author: Mike Sixsmith ISBN: 0728707802 - Fermacell reference section 'Wall-Lining Material'.



### Fermacell Gypsum Fibreboards are produced for use in commercial and domestic construction projects as a Dry Lining board for partitions, linings, ceilings, fire protection, flooring and a cladding backerboard.

COSHH Data Sheets for all Fermacell products including accessories are available, please contact our Technical Department on **+44 (0) 121 311 3480** or email **Fermacell-uk@xella.com**

At Fermacell, we take our responsibilities for the health of people seriously, which is why we strive to ensure that where possible all of our products are safe from an environmental and health viewpoint.



### HEALTH AND SAFETY

Due to the multifunctional nature of Fermacell Gypsum Fibreboards, they are stored and used in both internal and external environments. Care must be taken when using Fermacell and its associated accessories in areas of limited ventilation and around other working personnel. Although Fermacell itself does not contain any dangerous chemicals, it is imperative that safe working practices are followed.

Health and Safety Executive Guidance Note EA44 outlines the general approach to control occupational exposure to airborne dust, but it should always be considered that good working practice will ensure that occupational exposure is minimised. When installing Fermacell boards these include:

- Ensure good ventilation when cutting Fermacell
- Use dust extractors where possible to minimise airborne dust contamination when cutting with power tools
- Use a dust mask that meets EN 149 specifications
- Avoid contact of the dry products with the skin
- Irrigate eyes immediately with water in the event of contact with dust
- Always wash exposed skin after use

### FERMACELL JOINTSTIK AND FLOOR GLUE

**Skin contact:** Wipe off uncured product with a paper towel or cotton pad. Wash skin thoroughly with soapy water. Cured product should not be removed. Please note: should skin irritation persist obtain medical assistance.

**Eye contact:** Keep the eyelids open and rinse thoroughly with clean running water, and obtain medical assistance immediately.

**Ingestion:** DO NOT induce vomiting. Seek IMMEDIATE medical assistance.

NB: Please refer to the SDS and DoP information on our products.

### HEALTH AND SAFETY

#### FERMACELL FINE SURFACE TREATMENT AND JOINT FILLER

**General information:** Wash soiled clothing before reuse.

**Inhalation:** Inhalation of dust when mixing or sanding may cause short term irritation. Use a dust mask that meets EN 149 specifications.

**Skin contact:** Flush and wash with water and soap.

**Eye Contact:** Rinse eyes immediately with clean water.

**Ingestion:** Drink plenty of milk or water.

Safe working habits and conditions also cover lifting of heavy materials (which should be undertaken in the correct manner using mechanical handling equipment where appropriate); cutting and handling of metal components (the wearing of gloves to avoid cuts and abrasions is recommended); and the avoidance of contact between the eyes and liquid products.

Please see the diagrams opposite for handling and storage guidance.

Where possible, Fermacell boards should be stored on a flat level base. They should be protected from moisture; wet boards should be allowed to dry out completely on a level surface before use. The stacking of boards on their edges can lead to deformation of the boards and damage to the edges. Boards should generally be carried upright and the use of board lifters is advised when fitting boards to ceilings.

Occupational Exposure Standards (OES) are reviewed annually by the Health and Safety Executive in the light of any new medical evidence.

Please contact our Technical Department on **+44 (0) 121 311 3480** or email **Fermacell-uk@xella.com** for further SDS and DoP information.

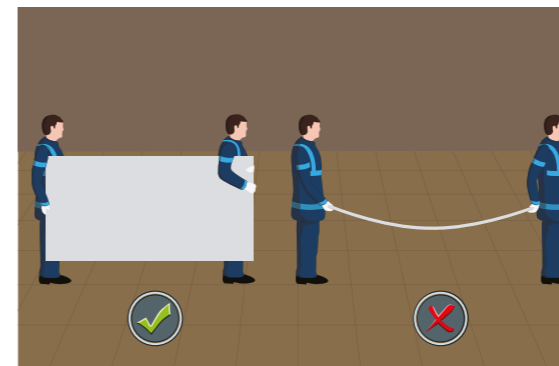
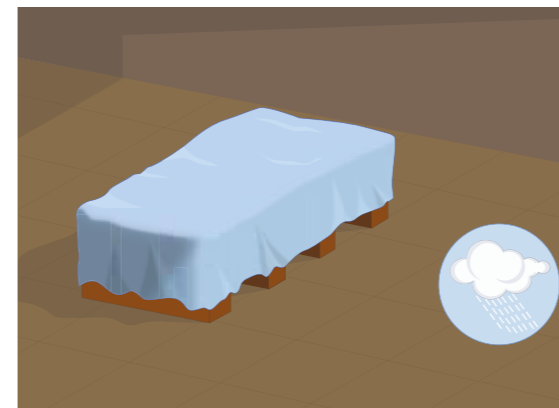
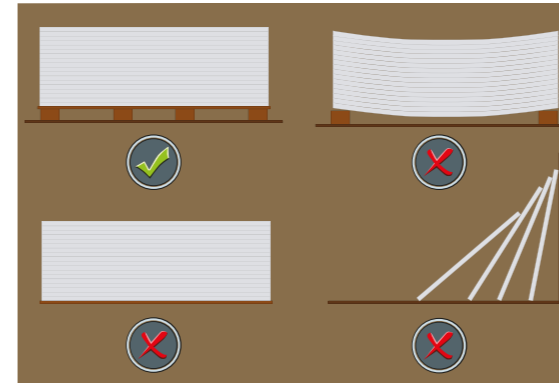

# Partitions

|                       |    |
|-----------------------|----|
| Introduction          | 29 |
| Accessories           | 30 |
| Detailed Overview     | 31 |
| Component Details     | 32 |
| Installation Overview | 37 |
| Performance Details   | 38 |

## MARKET SECTORS

- ▶ Arts
- ▶ Education
- ▶ Residential
- ▶ Healthcare
- ▶ Recreation
- ▶ Industrial/Office
- ▶ Prisons

## PERFORMANCE RATINGS



## Fermacell PERFORMANCE

- ▶ Impact – Severe duty, able to withstand impact from people as well as objects (door handles etc).
- ▶ Acoustics – Greater acoustic performance often with less layers than plasterboard constructions providing slimmer partitions.
- ▶ Loadbearing – The composition of Fermacell allows up to 50kg per fixing to be hung from Fermacell using a toggle bolt and 30kg from a single screw.
- ▶ Speed of construction – Due to the unique finishing system (FST) the overall installation of Fermacell is faster than plasterboard.
- ▶ Environmental – Fermacell boards are manufactured from recycled content and are recyclable. Decreasing the carbon footprint and increasing the BREEAM rating of the building.

Using Fermacell boards on either Metal or Timber partitions provides properties associated with solid masonry with the flexibility and speed of drywall, in a construction that is often thinner, quicker and cheaper to install.

This is largely achievable due to the all round performance of Fermacell boards that provide superior Fire, Acoustic and Impact performance, it eliminates wet trades making practical, technical and commercial sense.

### METAL STUD PARTITIONS

Fermacell boards are fixed to Fermacell steel studs<sup>(1)</sup>, which have a 0.6mm gauge metal thickness with a 50mm fixing face allowing a versatile, high performing and cost effective solution for domestic to commercial applications often achieving superior Fire, Acoustic and Impact resistance over drywall construction.

The excellent screw retention properties of Fermacell means that significantly fewer noggings or plywood is needed for dead load fixtures and fittings; this also allows junctions to be started from any point.

### TIMBER STUD PARTITIONS









These are more commonly used in domestic applications. Timber partitions provide versatility and performance including racking strength for timber framed properties. The ability of Fermacell to be stapled to timber studs means increased speed of fixing.

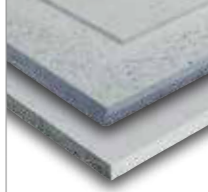







### TWIN FRAME SYSTEMS

Fermacell partitions achieve a number of advantages over masonry construction by reducing the weight, build time and cost often associated with masonry construction. We offer a number of Robust Detail Compliant solutions.

(1) Typically DIN standard

### ACCESSORIES

| COMPONENTS  |  |
|---|--|
|    | <p><b>Fermacell Gypsum Fibreboard</b><br/>Fermacell Square edge or Tapered edge.</p> <p><b>Thickness</b> 10mm, 12.5mm, 15mm and 18mm</p> <p><b>Sizes</b> 1200 x 1000mm to 1200 x 3000mm</p>  |
|    | <p><b>Fermacell Fine Surface Treatment</b><br/>For giving Fermacell boards a smooth finish prior to painting.</p> <p><b>Coverage</b> 4-5m<sup>2</sup> per ltr</p> <p><b>Pack Size</b> 3ltr or 10ltr</p>  |
|    | <p><b>Fermacell Joint Filler</b><br/>For filling 5-7mm gaps between boards &amp; stopping screw heads.</p> <p><b>Coverage</b> 5m<sup>2</sup> per kg for filling Tapered edge joints. 10m<sup>2</sup> for finishing glue joints and screw heads.</p> <p><b>Pack Size</b> 5kg or 20kg</p>        |
|  | <p><b>Fermacell Jointstik</b><br/>For edge glueing square edged Fermacell boards.</p> <p><b>Coverage</b> 20 lm / 310ml tube</p> <p><b>Pack Size</b> 310ml tubes</p>  |
|  | <p><b>Fermacell Mesh Jointing Tape</b><br/>Mesh tape or paper tape used to reinforce Tapered edge joints.</p> <p><b>Pack Size</b> 45m roll</p>   |
|  | <p><b>Fermacell Paper Jointing Tape</b><br/>Paper tape or mesh tape used to reinforce Tapered edge joints.</p> <p><b>Pack Size</b> 75m roll</p>  |
|  | <p><b>30/40/55mm Fermacell Screws</b><br/>For fixing Fermacell boards to steel and timber subframes.</p> <p><b>Coverage</b> 13 screws per m<sup>2</sup> for walls (for each side) 30 screws per m<sup>2</sup> for ceilings</p> <p><b>Pack Size</b> Box of 250 screws or box of 1000 screws</p> |
|  | <p><b>Fermacell Powerpanel H<sub>2</sub>O</b><br/>12.5mm thickness.</p> <p><b>Size</b> 1200 x 1000mm, 1200 x 2600mm or 1200 x 3000mm</p>   |

| ACCESSORIES   |   |
|---|---|
|    | <p><b>Fermacell Board Knife</b><br/>For scoring and snapping Fermacell boards.</p>  |
|    | <p><b>Fermacell Spatula</b><br/>For applying Fine Surface Treatment.</p> <p><b>Size</b> 250mm</p>   |
|    | <p><b>DIN steel profiles - e.g fermacell steel range</b></p> <p><b>Size</b> Nominal 0.6 gauge 50mm fixing face</p>  |
|  | <p><b>35/40/50mm Fermacell Powerpanel Screws</b><br/>For fixing Powerpanel H<sub>2</sub>O boards to steel or studs.</p> <p><b>Coverage</b> 13 screws per m<sup>2</sup> for walls (for each side) 30 screws per m<sup>2</sup> ceilings</p> <p><b>Pack Size</b> 250/500</p> |
|  | <p><b>Fermacell Powerpanel H<sub>2</sub>O Surface Finish</b><br/>Cement-based surface covering for a smooth plaster finish, without the need for reinforcement mesh. Colour: grey.</p> <p><b>Coverage</b> 1ltr at 1mm thickness</p> <p><b>Pack Size</b> 10ltr</p>         |
|  | <p><b>Fermacell Primer/Sealer</b><br/>For sealing floors, walls and ceilings prior to waterproof applications or tiling.</p> <p><b>Coverage</b> Approx. 100-200 g / m<sup>2</sup> depending on substrate and dilution</p> <p><b>Pack Size</b> 5kg bottle</p>              |
|  | <p><b>Fermacell Flexible Sealing Tape</b><br/>For sealing and waterproofing at corners.</p> <p><b>Coverage</b> As required</p> <p><b>Pack Size</b> 5m long, 12 cm wide 0.5kg 50m long, 12 cm wide 1kg</p>   |
|  | <p><b>Fermacell Waterproofing Application</b><br/>For sealing all splashback areas prior to tiling.</p> <p><b>Coverage</b> 4 - 6m<sup>2</sup> per 5kg bucket 16 - 25m<sup>2</sup> per 20kg bucket</p> <p><b>Pack Size</b> 5kg or 20kg bucket</p>                          |

### METAL STUD CONSTRUCTION

Finishing Partitions – following stopping of screws or staples and filling of joints, Fermacell accepts a range of finishes. Fermacell FST (Fine Surface Treatment) is used as an alternative to plastering. Refer to finishing section of manual for guidelines on FST, plastering, tiling or wall papering.

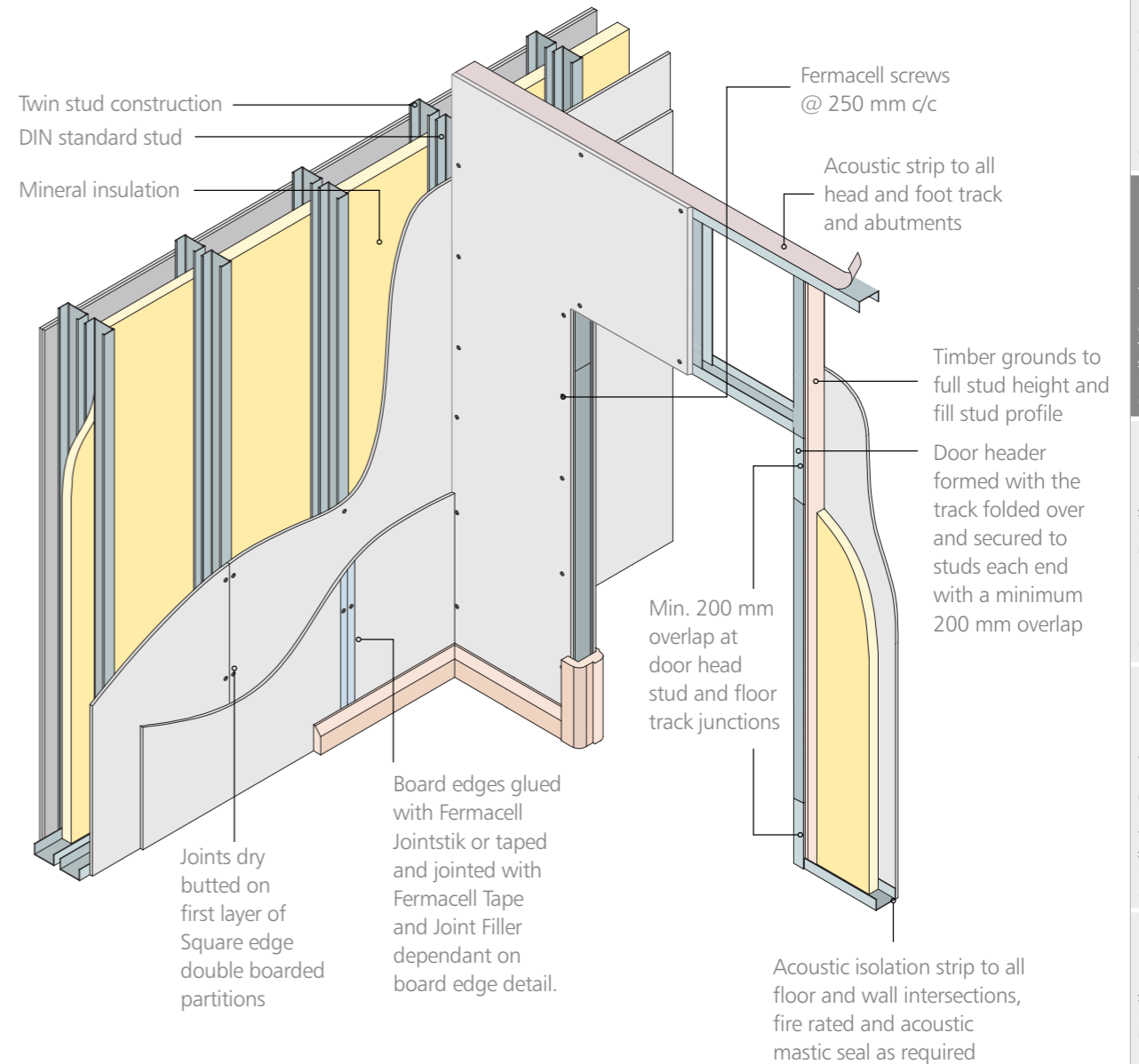

Fermacell Board should be fixed at max 250mm centres for partitions applications.



### JUNCTIONS, CONNECTIONS, EXPANSION JOINTS

### JUNCTIONS, CONNECTIONS, EXPANSION JOINTS

#### WALL AND CEILING JUNCTIONS WITH SINGLE-LAYER FERMACELL BOARDING

##### Separate wall and ceiling connections

Where Fermacell abuts other materials such as plaster, exposed concrete, masonry, steel or wood, care must be taken as each has a different differential movement rate (expansion and contraction with environmental changes).

(1) Junctions with elastic/flexible sealing material.

The back of the profile being fixed to the wall must be backed with an isolation strip (for fire and acoustic purposes). Any gaps can then be filled with a flexible sealant which has a permanent expansion of at least 20%. Nominally the gap left should be a minimum of 3–5mm.

(2) Junctions using Fermacell Joint Filler.

Fit studwork and isolation material. When fixing the boards to the studs, leave a 5–7mm gap and fill with Fermacell Joint Filler.

For fire resistance requirements:

Use a fire rated isolation strip. Rockwool type material should be of a thickness  $\leq 5$ mm.

- (1) Junctions with sealing material
- (2) Junctions with Fermacell Joint Filler

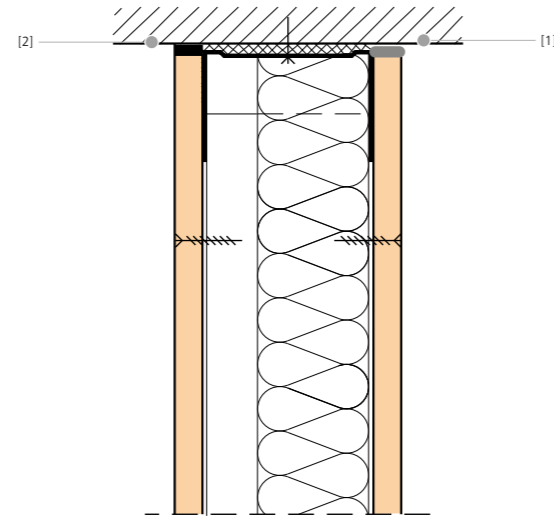

#### DEFLECTION HEAD CONNECTIONS

##### Deflection head details

Deflection head details are required where deflection is expected to exceed 10mm.

There are three sections which must have the same minimum distance left for the deflection head to work. These are:-

1. The distance from the top of the board to the Soffit.
2. The distance from the top of the stud to the head track.
3. The distance from the bottom of the head track leg to the first fixing into the stud.

A = Deflection  $\leq 20$ mm, maximum 25mm using timber at the head

Fermacell partition, single-layer boarding, F-30 B/F 60-B, Deflection Head Detail

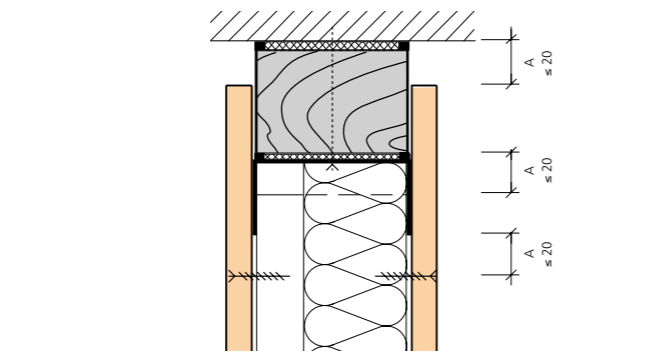

Deflection Head constructions will give a reduction in overall acoustic performance unless special detailing is used.

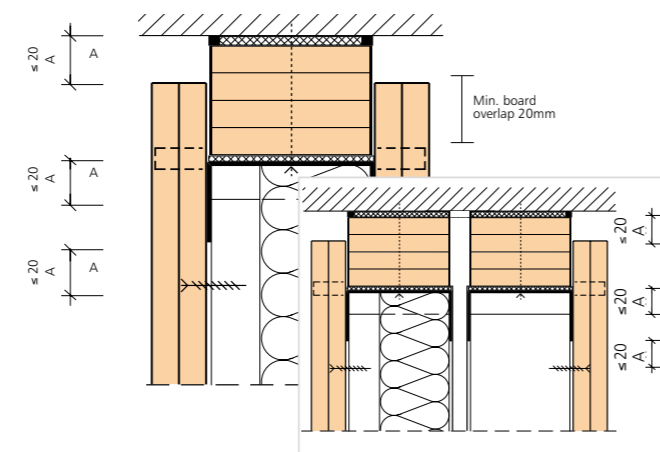

Dimension A is shown here as 20mm. Contact our Technical Department for Deflections in excess of 25mm

Fermacell partition, double-layer boarding, F 90-A, Deflection Head Detail

Fermacell separated stud partition, double-layer boarding, F 90-A, Deflection Head Detail

#### T-JUNCTIONS

T-junctions with single or double-layer boarding, with C stud fixed to Fermacell Board.

- (1) Fermacell boards 12.5 or 10mm
- (2) Insulating material
- (3) Edge isolation strips
- (4) Stud profile
- (5) Header or footer track
- (7) Fermacell screws 3.9 x 30mm
- (8) Staples, galvanised, for fixing Fermacell in Fermacell
- (9) Fermacell Joint Filler

For fire rated junctions greater than 60 minutes performance, contact our Technical Department.

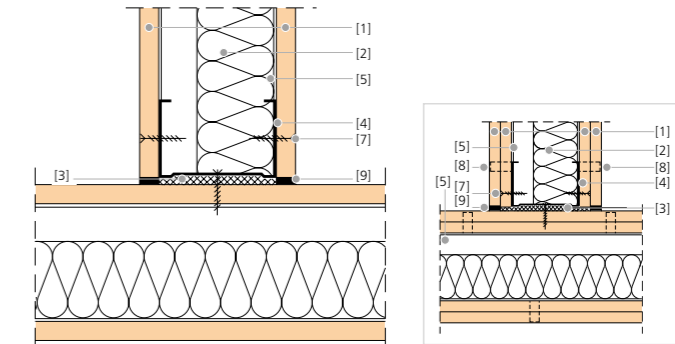

#### CORNER DETAIL

Corner connections with single or double-layer boarding.

- (1) Fermacell boards 12.5 or 10mm
- (2) Insulating material
- (4) Stud profile
- (5) Header or footer track
- (6) Inner corner profile
- (7) Fermacell screws 3.9 x 30mm
- (8) Staples, galvanised, for fixing Fermacell in Fermacell
- (9) Fermacell Joint Filler

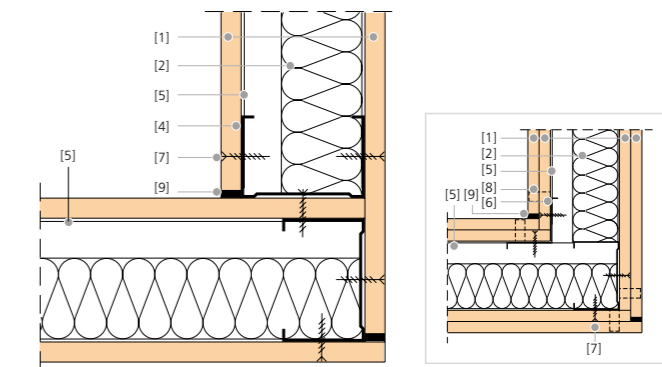

#### ACOUSTIC T-JUNCTIONS

Wall T-junction with interrupted longitudinal flanking transmission and inner corner profile.

- (1) Fermacell boards 12.5 or 10mm
- (2) Insulating material
- (5) Header or footer track
- (6) Header or footer track
- (7) Fermacell screws 3.9 x 30mm
- (8) Staples, galvanised, for fixing Fermacell in Fermacell
- (9) Fermacell Joint Filler

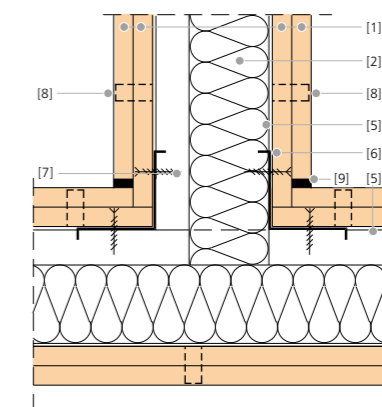

Standard Details are available from Fermacell. Please contact the Technical Department Helpline on +44 (0) 121 311 3480

### JUNCTIONS, CONNECTIONS AND EXPANSION JOINTS

#### MOVEMENT CONTROL JOINTS

##### Movement control joints

Movement control joints are required in Fermacell steel stud partitions. They should also be placed in linings or partitions to mirror any structural movement joints in the main shell of the building.

**The spacing of movement control joints is dependant on the jointing method used. When using the adhesive Jointstik method then they can be placed at maximum 10m intervals. When using the Joint filler method or Tapered edge board method then they can be placed at maximum intervals of 8m.**

Where required, movement joints and end wall movement joints can be used together to provide the simplest solution.

A = Degree of expansion in mm

Minimum expansion allowance = 10mm

For Powerpanel H<sub>2</sub>O Movement Joints must be placed at maximum 8m intervals.

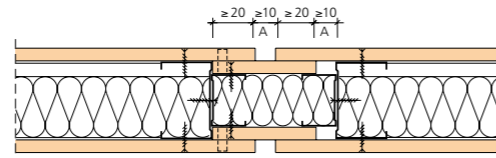

Fermacell stud partition wall, single-layered boarding F 30-A/F 60-A. Expansion joint

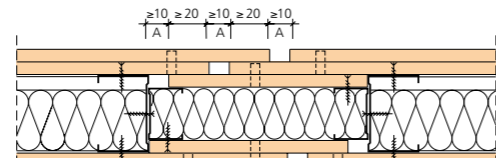

Fermacell stud partition wall, double-layered boarding, F 90-A. Expansion joint

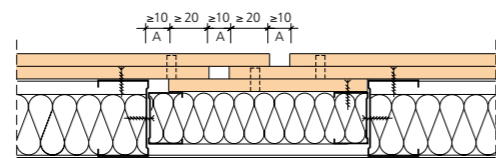

Fermacell separated stud partition wall, double-layer boarding, F 90-A. Expansion joint

#### CURVED PARTITIONS

##### Bending Fermacell Gypsum Fibreboards

When preparing curved wall and ceiling structures using standard size 10mm and 12.5mm Fermacell boards, there are two methods of application. These depend on the areas where the curved walls are to be used and the required radius.

For a radius  $\geq 4000$ mm, use dry bending with stud spacing  $\leq 300$ mm. In this case, standard size boards are fixed lengthways on to the studs.

##### For 10mm Fermacell only

For a radius between  $\leq 4000$ mm to  $\geq 1500$ mm, wet bending (locally, on site) is possible.

For further details please contact our technical department.

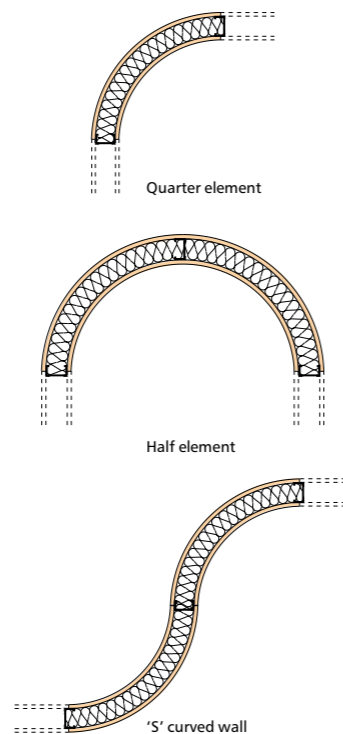

### JUNCTIONS, CONNECTIONS AND EXPANSION JOINTS

#### REDUCTION JUNCTIONS

##### Wall movement joints and façade junctions.

Exterior facades, principally curtain walls, can be subject through wind loads, causing pressure and suction movements, and must be designed accordingly. Ensure that no structural forces affect the Fermacell boards and that the required sound-reduction and fire resistance characteristics are met.

Fermacell partition, single-layer boarding, F 30-A /F 60-A. Wall movement joint and/or façade junction with a steel stud and strips of board.

A = Expansion in mm

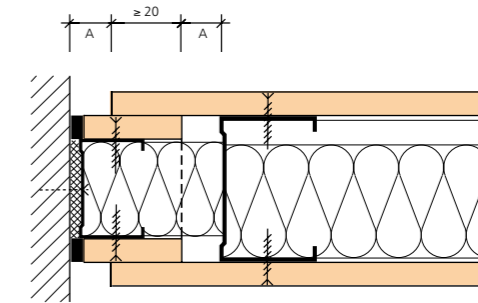

##### Reduction junctions (Tapered wall and façade junctions).

When joining partitions to narrow building components (such as window posts), the thickness of the partition must be reduced to match the size of the junction section. To compensate acoustically, a lead sheet can be fitted in the reduced wall section on one or both sides.

Reduction junction for a double stud wall with sound reduction requirements

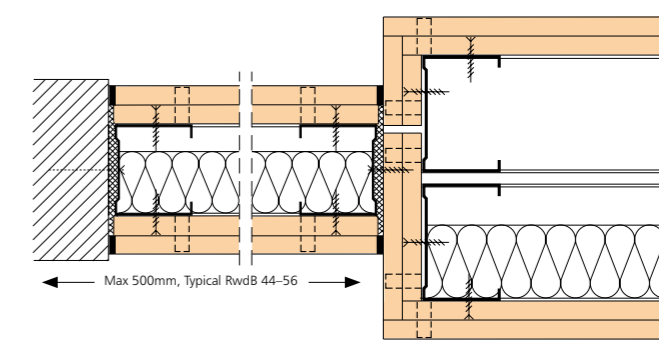

#### SKIRTING

##### Skirting and Recessed Skirting

The junction of the Fermacell boards with the floor can be constructed in various ways to meet function and design requirements.

- Conventional skirting
- Recessed skirting
- Recessed skirting partition with double-layer boarding – to maintain the sound reduction and fire resistance, additional layers of board material should be built into the wall cavity.

Recessed skirting F 90-A according to report on DIN 4102 Part 4 (sizes in mm)

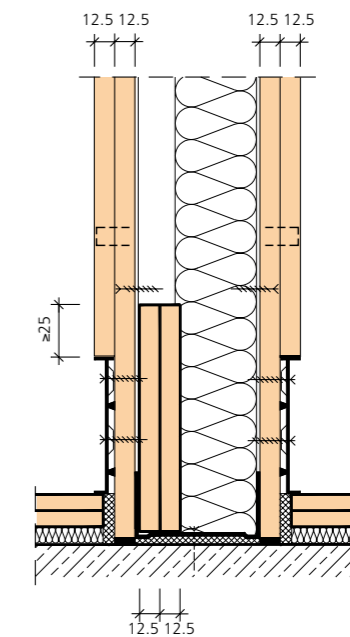

### DOORS AND WINDOWS

### STEEL STUDS

#### DOOR MOUNTINGS, FRAMES AND WALL OPENINGS

##### Door mountings, frames, glazing and wall openings

Please refer to the Fermacell Data Sheet about door reinforcement recommendations.

Frame fixing to steel studs with timber inserts  
 (1) Fermacell (2) Header/footer track (3) Rockwool (4) C stud (5) Door frame (6) Timber reinforcement

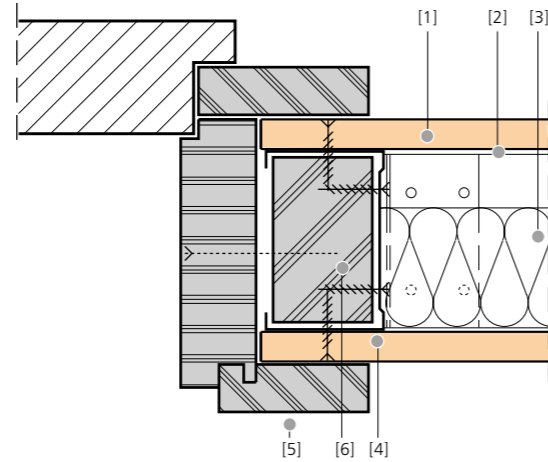

#### FIXING DOOR FRAMES USING 2MM THICK DOOR REINFORCEMENT KITS

##### Door frame installation methods

There are many different methods of fixing that can be used for securing door frames to/in Fermacell partitions and fire walls. These depend on the room height (wall height), door width, weight of the door leaf, including door furniture, etc.

Please see the Fermacell datasheet regarding door frame reinforcement.

The guidelines for different door support types are based on the following door weights as a guide. Double door and leaf and a half doors will always require additional support.

≤ 25kg doors – Timber inserts are required up to 2.5m of the partition height.

25kg – 60kg doors – Timber inserts are required to a minimum of 3m. An L bracket is required at the head of the timber support.

60kg + doors – Steel Door Reinforcement kit and timber insert. Alternatively, call the Technical Department for further assistance.

When boarding around doors and openings it is imperative that joints do not run vertically from corners. The boards should be cut to allow joints to sit above the door head and offset from the edge of the door/opening by > 200mm.

##### Installation methods for glazing

Where glazing details are to be installed in Fermacell walls, additional support will be required.

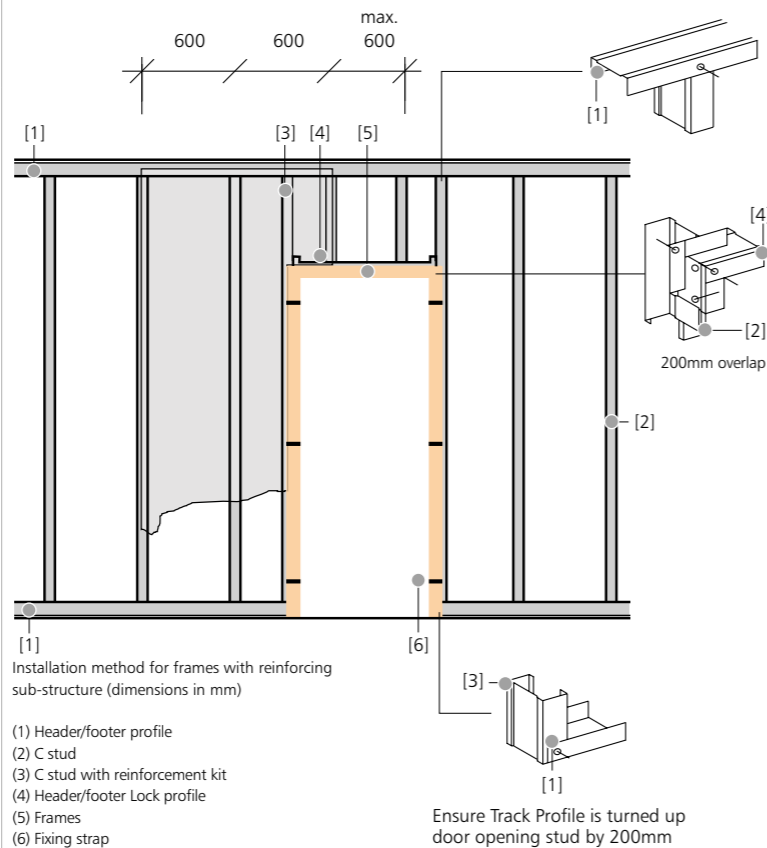

NB: For any openings in Fire Rated Partitions, close off all edges with the same number of layer of board as on the face of the studs.

#### STEP ONE



Ensure the floor is clean and flat; mark out the line of the partition allowing for the width of the Fermacell boards.

#### STEP TWO



Fix the base track to the floor at 600mm centres using suitable fixings. Isolating strips must be used to ensure the correct Acoustic and Fire performance.

#### STEP THREE



Once the base track is fixed, plumb the top track in to position and fix with Fermacell screws or proprietary fixings. Fix end studs to the substrates ensuring adequate acoustic insulation at 600mm centres.

#### STEP FOUR



The intermediate studs should be cut no more than 10mm shorter than the floor to ceiling height and not mechanically fixed. They should be installed facing the same direction. Door openings should be marked and the studs either side of the door opening fixed.

#### STEP FIVE



Install insulation (if required) making sure that there is a cavity between the insulation and one face of the Fermacell boards. Cut the Fermacell boards 10mm less than the room height and install leaving gaps as required for jointing to ceiling. (See step 2 page 60).

#### STEP SIX



Screw fix the boards as per the fixing sequence (7 & 8) at 250 maximum centers using Fermacell screws. The vertical joints can be "mirrored" through the partition when using Fermacell Jointstik. Do not fix the boards to the top and bottom tracks.

#### STEP SEVEN

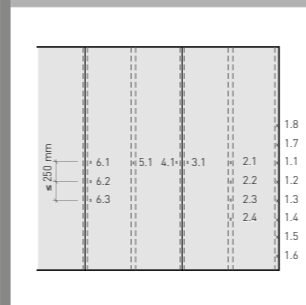

Ensure the boards are fixed as per this fixing sequence to ensure a flat and uniform surface.



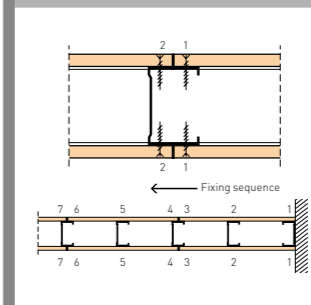

#### STEP EIGHT





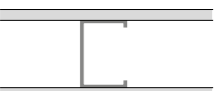
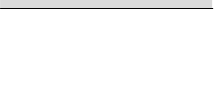

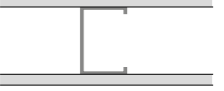
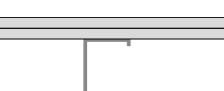

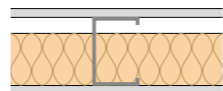
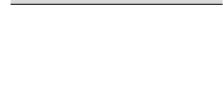

Screw fix to the open side of the stud first working from the end of the partition.

### Fermacell PARTITION WALLS ON STEEL WALLS WITHOUT INSULATION

### Fermacell PARTITION WALLS ON STEEL WALLS WITHOUT INSULATION

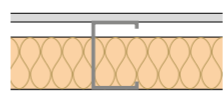
| SYSTEM SPECIFICATIONS   |         |  | Wall Weight       | Wall Height<br>(Without Fire Rating) | Wall Height<br>(With Fire Rating) | Wall Thickness | Fire Rating | Sound Insulation | BS 5234 |
|---|---------|--|-------------------|--------------------------------------|-----------------------------------|----------------|-------------|------------------|---------|
|   |         |  | kg/m <sup>2</sup> | m                                    | m                                 | mm             | mins        | R <sub>w</sub>   | Grade   |
| <b>1S15</b>   |         |  |                   |                                      |                                   |                |             |                  |         |
|    | Studs   | 50mm DIN standard studs @ 600mm centres                            | 31                | 3.42                                 | 3.42                              | 75             | 30          | 41               | Heavy*  |
|   | Facings | 1 layer 12.5mm Fermacell Board each side                           |                   |                                      |                                   |                |             |                  |         |
|    | Studs   | 75mm DIN standard studs @ 600mm centres                            | 32                | 4.75                                 | 4.75                              | 100            | 30          | 43               | Severe  |
|   | Facings | 1 layer 12.5mm Fermacell Board each side                           |                   |                                      |                                   |                |             |                  |         |
|    | Studs   | 100mm DIN standard studs @ 600mm centres                           | 33                | 5.98                                 | 5.98                              | 125            | 30          | 43               | Severe  |
|   | Facings | 1 layer 12.5mm Fermacell Board each side                           |                   |                                      |                                   |                |             |                  |         |
| <b>1S15/2</b>   |         |  |                   |                                      |                                   |                |             |                  |         |
|    | Studs   | 75mm DIN standard studs @ 600mm centres                            | 38                | 3.7                                  | 3.7                               | 105            | 60          | 43               | Severe  |
|   | Facings | 1 layer 15mm Fermacell Board each side                             |                   |                                      |                                   |                |             |                  |         |
| <b>1S22</b>   |         |  |                   |                                      |                                   |                |             |                  |         |
|  | Studs   | 75mm DIN standard studs @ 600mm centres                            | 63                | 6.1                                  | 3.8                               | 125            | 60          | 52               | Severe  |
|   | Facings | 2 layers 12.5mm Fermacell Board each side or 12.5 + 10mm each side |                   |                                      |                                   |                |             |                  |         |
|  | Studs   | 100mm DIN standard studs @ 600mm centres                           | 63                | 8.65                                 | 4.84                              | 150            | 60          | 54               | Severe  |
|   | Facings | 2 layers 12.5mm Fermacell Board each side or 12.5 + 10mm each side |                   |                                      |                                   |                |             |                  |         |

\* - Interpolated Performance

| SYSTEM SPECIFICATIONS   |            |   | Wall Weight       | Wall Height<br>(Without Fire Rating) | Wall Height<br>(With Fire Rating) | Wall Thickness | Fire Rating | Sound Insulation | BS 5234 |
|---|------------|---|-------------------|--------------------------------------|-----------------------------------|----------------|-------------|------------------|---------|
|   |            |   | kg/m <sup>2</sup> | m                                    | m                                 | mm             | mins        | R <sub>w</sub>   | Grade   |
| <b>1S11</b>   |            |   |                   |                                      |                                   |                |             |                  |         |
|    | Studs      | 50mm DIN standard studs @ max 500mm centres         | 27                | 3.75                                 | N/A                               | 70             | 30          | 48               | Heavy*  |
|   | Facings    | 1 layer 10mm Fermacell Board each side              |                   |                                      |                                   |                |             |                  |         |
|   | Insulation | 40mm mineral stone wool density 40kg/m <sup>3</sup> |                   |                                      |                                   |                |             |                  |         |
|    | Studs      | 75mm DIN standard studs @ max 500mm centres         | 28                | 4.25                                 | N/A                               | 95             | 30          | 48               | Heavy*  |
|   | Facings    | 1 layer 10mm Fermacell Board each side              |                   |                                      |                                   |                |             |                  |         |
|   | Insulation | 40mm mineral stone wool density 40kg/m <sup>3</sup> |                   |                                      |                                   |                |             |                  |         |
|    | Studs      | 50mm DIN standard studs @ 600mm centres             | 34                | 3.7                                  | 3.32                              | 75             | 30          | 48               | Heavy*  |
|   | Facings    | 1 layer 12.5mm Fermacell Board each side            |                   |                                      |                                   |                |             |                  |         |
|   | Insulation | 40mm mineral stone wool density 40kg/m <sup>3</sup> |                   |                                      |                                   |                |             |                  |         |
|    | Studs      | 75mm DIN standard studs @ 600mm centres             | 34                | 4                                    | 4.65                              | 100            | 30          | 52               | Severe  |
|   | Facings    | 1 layer 12.5mm Fermacell Board each side            |                   |                                      |                                   |                |             |                  |         |
|   | Insulation | 60mm mineral stone wool density 20kg/m <sup>3</sup> |                   |                                      |                                   |                |             |                  |         |
|   | Studs      | 100mm DIN standard studs @ 600mm centres            | 35                | 5.7                                  | 5.89                              | 125            | 30          | 52               | Severe  |
|   | Facings    | 1 layer 12.5mm Fermacell Board each side            |                   |                                      |                                   |                |             |                  |         |
|   | Insulation | 60mm mineral stone wool density 20kg/m <sup>3</sup> |                   |                                      |                                   |                |             |                  |         |
| <b>1S21</b>   |            |   |                   |                                      |                                   |                |             |                  |         |
|  | Studs      | 75mm DIN standard studs @ 600mm centres             | 35                | 5                                    | 4                                 | 100            | 60          | 52               | Severe  |
|   | Facings    | 1 layer 12.5mm Fermacell Board each side            |                   |                                      |                                   |                |             |                  |         |
|   | Insulation | 40mm mineral stone wool density 45kg/m <sup>3</sup> |                   |                                      |                                   |                |             |                  |         |
|  | Studs      | 75mm DIN standard studs @ 600mm centres             | 35                | 5                                    | 4                                 | 100            | 60          | 54               | Severe  |
|   | Facings    | 1 layer 12.5mm Fermacell Board each side            |                   |                                      |                                   |                |             |                  |         |
|   | Insulation | 60mm mineral stone wool density 30kg/m <sup>3</sup> |                   |                                      |                                   |                |             |                  |         |
|  | Studs      | 100mm DIN standard studs @ 600mm centres            | 35                | 5.7                                  | 5.03                              | 125            | 60          | 52               | Severe  |
|   | Facings    | 1 layer 12.5mm Fermacell Board each side            |                   |                                      |                                   |                |             |                  |         |
|   | Insulation | 40mm mineral stone wool density 45kg/m <sup>3</sup> |                   |                                      |                                   |                |             |                  |         |
|  | Studs      | 100mm DIN standard studs @ 600mm centres            | 35                | 5.7                                  | 5.03                              | 125            | 60          | 54               | Severe  |
|   | Facings    | 1 layer 12.5mm Fermacell Board each side            |                   |                                      |                                   |                |             |                  |         |
|   | Insulation | 60mm mineral stone wool density 30kg/m <sup>3</sup> |                   |                                      |                                   |                |             |                  |         |

\* - Interpolated Performance

### Fermacell PARTITION WALLS ON STEEL WALLS WITH INSULATION

### Fermacell PARTITION WALLS ON STEEL WALLS WITH INSULATION

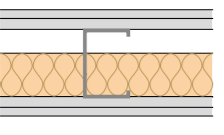
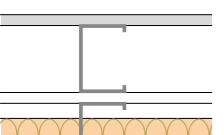
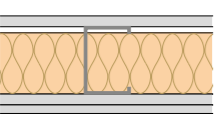
| SYSTEM SPECIFICATIONS |  | kg/m <sup>2</sup> | m                                 | m                              | mm             | mins        | R <sub>w</sub>   | Grade   |
|-----------------------|--|-------------------|-----------------------------------|--------------------------------|----------------|-------------|------------------|---------|
|                       |  | Wall Weight       | Wall Height (Without Fire Rating) | Wall Height (With Fire Rating) | Wall Thickness | Fire Rating | Sound Insulation | BS 5234 |
| <b>1S24</b>           |                           |                   |                                   |                                |                |             |                  |         |
| Studs                 | 50mm DIN standard studs @ 600mm centres  |                   |                                   |                                |                |             |                  |         |
| Facings               | 1 layer 12.5mm Fermacell Board each side plus 1 layer 10mm Fermacell Board each outer side                 | 58                | 4                                 | 2.75                           | 95             | 60          | 59               | Heavy*  |
| Insulation            | 40mm mineral stone wool density 20kg/m <sup>3</sup>  |                   |                                   |                                |                |             |                  |         |
| <b>1S25</b>           |                           |                   |                                   |                                |                |             |                  |         |
| Studs                 | 2 x 75mm DIN standard studs @ 600mm centres  |                   |                                   |                                |                |             |                  |         |
| Facings               | 1 layer 12.5mm Fermacell Board each side   | 38                | 3.89                              | 3.89                           | ≥185           | 60          | 60               | Severe  |
| Insulation            | 70mm mineral stone wool density 30kg/m <sup>3</sup>  |                   |                                   |                                |                |             |                  |         |
| Studs                 | 2 x 75mm DIN standard studs @ 600mm centres  |                   |                                   |                                |                |             |                  |         |
| Facings               | 1 layer 12.5mm Fermacell Board each side   | 38                | 3.89                              | 3.89                           | ≥185           | 60          | 57               | Severe  |
| Insulation            | 40mm mineral stone wool density 45kg/m <sup>3</sup>  |                   |                                   |                                |                |             |                  |         |
| <b>1S29</b>           |                         |                   |                                   |                                |                |             |                  |         |
| Studs                 | 50mm DIN standard studs @ 600mm centres  |                   |                                   |                                |                |             |                  |         |
| Facings               | 1 layer 12.5mm Fermacell Board each side plus 1 layer 10mm Fermacell Board outer side                      | 46                | 4                                 | 2.47                           | 85             | 60          | 54               | Heavy*  |
| Insulation            | 40mm mineral stone wool density 50kg/m <sup>3</sup>  |                   |                                   |                                |                |             |                  |         |
| Studs                 | 75mm DIN standard studs @ 600mm centres  |                   |                                   |                                |                |             |                  |         |
| Facings               | 1 layer 12.5mm Fermacell Board each side plus 1 layer 10mm Fermacell Board outer side                      | 46                | 5                                 | 3.51                           | 110            | 60          | 56               | Severe  |
| Insulation            | 70mm mineral stone wool density 30kg/m <sup>3</sup> or 60mm mineral stone wool density 35kg/m <sup>3</sup> |                   |                                   |                                |                |             |                  |         |
| Studs                 | 100mm DIN standard studs @ 600mm centres   |                   |                                   |                                |                |             |                  |         |
| Facings               | 1 layer 12.5mm Fermacell Board each side plus 1 layer 10mm Fermacell Board outer side                      | 46                | 6.65                              | 4.56                           | 135            | 60          | 57               | Severe  |
| Insulation            | 70mm mineral stone wool density 30kg/m <sup>3</sup> or 60mm mineral stone wool density 35kg/m <sup>3</sup> |                   |                                   |                                |                |             |                  |         |

\* - Interpolated Performance

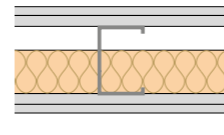
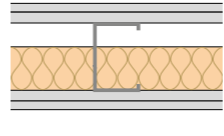
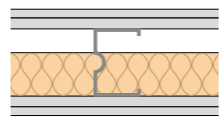
| SYSTEM SPECIFICATIONS  |  | kg/m <sup>2</sup> | m                                 | m                              | mm             | mins        | R <sub>w</sub>   | Grade   |
|------------------------|--|-------------------|-----------------------------------|--------------------------------|----------------|-------------|------------------|---------|
|                        |  | Wall Weight       | Wall Height (Without Fire Rating) | Wall Height (With Fire Rating) | Wall Thickness | Fire Rating | Sound Insulation | BS 5234 |
| <b>1S31</b>            |                         |                   |                                   |                                |                |             |                  |         |
| Studs                  | 75mm DIN standard studs @ 600mm centres  |                   |                                   |                                |                |             |                  |         |
| Facings                | 1 layer 12.5mm Fermacell Board each side plus 1 layer 10mm Fermacell Board each outer side                 | 58                | 5.75                              | 5.5                            | 120            | 90          | 62               | Severe  |
| Insulation             | 60mm mineral stone wool density 30kg/m <sup>3</sup>  |                   |                                   |                                |                |             |                  |         |
| Studs                  | 75mm DIN standard studs @ 600mm centres  |                   |                                   |                                |                |             |                  |         |
| Facings                | 2 layers 12.5mm Fermacell Board each side  | 64                | 6.1                               | 5.5                            | 125            | 90          | 62               | Severe  |
| Insulation             | 60mm mineral stone wool density 30kg/m <sup>3</sup>  |                   |                                   |                                |                |             |                  |         |
| Studs                  | 100mm DIN standard studs @ 600mm centres   |                   |                                   |                                |                |             |                  |         |
| Facings                | 1 layer 12.5mm Fermacell Board plus 1 layer 10mm Fermacell Board each outer side                           | 59                | 8.2                               | 6.5                            | 145            | 90          | 62               | Severe  |
| Insulation             | 60mm mineral stone wool density 30kg/m <sup>3</sup>  |                   |                                   |                                |                |             |                  |         |
| Studs                  | 100mm DIN standard studs @ 600mm centres   |                   |                                   |                                |                |             |                  |         |
| Facings                | 2 layers 12.5mm Fermacell Board each side  | 65                | 8.65                              | 6.5                            | 150            | 90          | 62               | Severe  |
| Insulation             | 60mm mineral stone wool density 30kg/m <sup>3</sup>  |                   |                                   |                                |                |             |                  |         |
| <b>1S31 120 minute</b> |                       |                   |                                   |                                |                |             |                  |         |
| Studs                  | 75mm DIN standard studs @ 600mm centres  |                   |                                   |                                |                |             |                  |         |
| Facings                | 2 layers 12.5mm Fermacell Board each side  | 65                | 6                                 | 3.04                           | 125            | 120         | 62               | Severe  |
| Insulation             | 50mm mineral stone wool density 50kg/m <sup>3</sup>  |                   |                                   |                                |                |             |                  |         |
| <b>1S31W</b>           |                       |                   |                                   |                                |                |             |                  |         |
| Studs                  | 75mm acoustic DIN standard studs @ 600mm centres   |                   |                                   |                                |                |             |                  |         |
| Facings                | 1 layer 12.5mm Fermacell Board each side plus 1 layer 10mm Fermacell Board each outer side                 | 58                | 3.5                               | 3.5                            | 120            | 90          | 64               | Heavy*  |
| Insulation             | 60mm mineral stone wool density 50kg/m <sup>3</sup> or 60mm mineral stone wool density 35kg/m <sup>3</sup> |                   |                                   |                                |                |             |                  |         |
| Studs                  | 100mm acoustic DIN standard studs @ 600mm centres  |                   |                                   |                                |                |             |                  |         |
| Facings                | 1 layer 12.5mm Fermacell Board each side plus 1 layer 10mm Fermacell Board each outer side                 | 59                | 3.5                               | 3.5                            | 145            | 90          | 64               | Heavy*  |
| Insulation             | 60mm mineral stone wool density 50kg/m <sup>3</sup> or 60mm mineral stone wool density 35kg/m <sup>3</sup> |                   |                                   |                                |                |             |                  |         |

When using Acoustic Studs, confirm the test data with the Stud manufacturer first  
\*Heavy due to deflection on studs due to resilient nature.

### Fermacell PARTITION WALLS ON STEEL WALLS WITH INSULATION

### Fermacell PARTITION WALLS ON STEEL WALLS WITH INSULATION

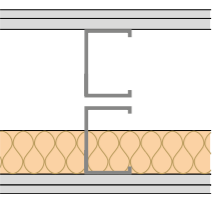
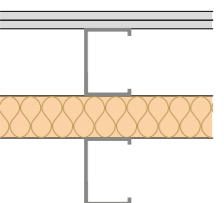
| SYSTEM SPECIFICATIONS  |            | kg/m <sup>2</sup>  | m    | m    | mm   | mins | R <sub>w</sub> | Grade  |
|--|------------|--|------|------|------|------|----------------|--------|
| <b>1S32</b>  |            |  |      |      |      |      |                |        |
|   | Studs      | 2 x 50mm DIN standard studs @ 600mm centres  |      |      |      |      |                |        |
|  | Facings    | 1 layer 12.5mm Fermacell Board each side plus 1 layer 10mm Fermacell Board each outer side                 |      |      |      |      |                |        |
|  | Insulation | 50mm mineral stone wool density 50kg/m <sup>3</sup> or 60mm mineral stone wool density 35kg/m <sup>3</sup> |      |      |      |      |                |        |
|  | Studs      | 2 x 75mm DIN standard studs @ 600mm centres  |      |      |      |      |                |        |
|  | Facings    | 1 layer 12.5mm Fermacell Board each side plus 1 layer 10mm Fermacell Board each outer side                 |      |      |      |      |                |        |
|  | Insulation | 50mm mineral stone wool density 50kg/m <sup>3</sup> or 60mm mineral stone wool density 35kg/m <sup>3</sup> |      |      |      |      |                |        |
|  |            | 60   | 3.05 | 3.05 | ≥150 | 90   | 64             | Heavy* |
|  |            | 60   | 4    | 3.5  | ≥200 | 90   | 64             | Severe |
| <b>1S32/2</b>  |            |  |      |      |      |      |                |        |
|  | Studs      | 2 x 75mm DIN standard studs @ 500mm centres  |      |      |      |      |                |        |
|  | Facings    | 2 layers 10mm or 12.5 + 10mm Fermacell Board each side   |      |      |      |      |                |        |
|  | Insulation | 60 - 70mm mineral stone wool density 33-60kg/m <sup>3</sup>  |      |      |      |      |                |        |
|  |            | 61   | 3.8  | 3.8  | ≥205 | 60   | 64             | Severe |

Robust detail solution must have a minimum cavity gap of 200mm between inner board faces.

\* - Interpolated Performance

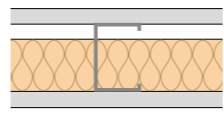
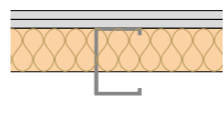
| SYSTEM SPECIFICATIONS  |            | kg/m <sup>2</sup>  | m   | m    | mm   | mins | R <sub>w</sub> | Grade  |
|--|------------|--|-----|------|------|------|----------------|--------|
| <b>1S33</b>  |            |  |     |      |      |      |                |        |
|   | Studs      | 75mm DIN standard studs @ 900mm centres  |     |      |      |      |                |        |
|  | Facings    | 1 layer 18mm Fermacell Board each side   |     |      |      |      |                |        |
|  | Insulation | 60mm mineral stone wool density 50kg/m <sup>3</sup>  |     |      |      |      |                |        |
|  | Studs      | 100mm DIN standard studs @ 900mm centres   |     |      |      |      |                |        |
|  | Facings    | 1 layer 18mm Fermacell Board each side   |     |      |      |      |                |        |
|  | Insulation | 60mm mineral stone wool density 50kg/m <sup>3</sup>  |     |      |      |      |                |        |
|  | Studs      | 100mm DIN standard studs @ 600mm centres   |     |      |      |      |                |        |
|  | Facings    | 1 layer 18mm Fermacell Board each side*  |     |      |      |      |                |        |
|  | Insulation | 80mm mineral stone wool density 50kg/m <sup>3</sup>  |     |      |      |      |                |        |
|  |            | 50   | 4   | 4    | 111  | 90   | 57             | Severe |
|  |            | 50   | 5.9 | 4.46 | 136  | 90   | 57             | Severe |
|  |            | 50   | 5.9 | 4.37 | 136  | 120  | 57             | Severe |
| <b>1S36</b>  |            |  |     |      |      |      |                |        |
|  | Studs      | 2 x 75mm DIN standard studs @ 600mm centres  |     |      |      |      |                |        |
|  | Facings    | 1 layer 12.5mm Fermacell Board each side plus 1 layer 10mm Fermacell Board each outer side |     |      |      |      |                |        |
|  | Insulation | 2 x 60mm mineral stone wool density 30kg/m <sup>3</sup>                                    |     |      |      |      |                |        |
|  | Studs      | 2 x 75mm DIN standard studs @ 600mm centres  |     |      |      |      |                |        |
|  | Facings    | 2 layers 12.5mm Fermacell Board each side  |     |      |      |      |                |        |
|  | Insulation | 2 x 60mm mineral stone wool density 30kg/m <sup>3</sup>                                    |     |      |      |      |                |        |
|  |            | 73   | 4.5 | 3.13 | ≥230 | 90   | 70             | Severe |
|  |            | 79   | 4.5 | 3.13 | ≥235 | 90   | 70             | Severe |

\* - F120 Solution

### Fermacell PARTITION WALLS ON STEEL WALLS WITH INSULATION

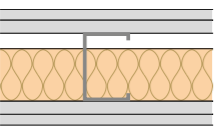

### Fermacell H<sub>2</sub>O PARTITION WALLS ON STEEL STUD

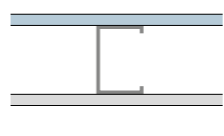
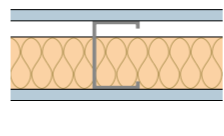
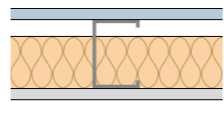
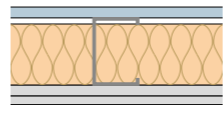

| SYSTEM SPECIFICATIONS  |            | kg/m <sup>2</sup>  | m                                 | m                              | mm             | mins        | R <sub>w</sub>   | Grade   |        |
|--|------------|--|-----------------------------------|--------------------------------|----------------|-------------|------------------|---------|--------|
|  |            | Wall Weight  | Wall Height (Without Fire Rating) | Wall Height (With Fire Rating) | Wall Thickness | Fire Rating | Sound Insulation | BS 5234 |        |
| <b>1S41</b><br> | Studs      | 75mm DIN standard studs @ 600mm centres  | 76                                | 5.5                            | 5.5            | 135         | 120              | 62      | Severe |
|  | Facings    | 1 layer 15mm Fermacell Board each side plus 1 layer 12.5mm Fermacell Board each outer side |                                   |                                |                |             |                  |         |        |
|  | Insulation | 50mm mineral stone wool density 50kg/m <sup>3</sup>  |                                   |                                |                |             |                  |         |        |
|  | Studs      | 100mm DIN standard studs @ 600mm centres   | 77                                | 6.5                            | 6.5            | 160         | 120              | 62      | Severe |
|  | Facings    | 1 layer 15mm Fermacell Board each side plus 1 layer 12.5mm Fermacell Board each outer side |                                   |                                |                |             |                  |         |        |
|  | Insulation | 50mm mineral stone wool density 50kg/m <sup>3</sup>  |                                   |                                |                |             |                  |         |        |
|  | Studs      | 125mm DIN standard studs @ 600mm centres   | 77                                | 7.5                            | 7.5            | 185         | 120              | 62      | Severe |
|  | Facings    | 1 layer 15mm Fermacell Board each side plus 1 layer 12.5mm Fermacell Board each outer side |                                   |                                |                |             |                  |         |        |
|  | Insulation | 50mm mineral stone wool density 50kg/m <sup>3</sup>  |                                   |                                |                |             |                  |         |        |

| SYSTEM SPECIFICATIONS   |   | kg/m <sup>2</sup>   | m                                 | m                              | mm             | mins        | R <sub>w</sub>   | Grade   |       |
|---|---|---|-----------------------------------|--------------------------------|----------------|-------------|------------------|---------|-------|
|   |   | Wall Weight   | Wall Height (Without Fire Rating) | Wall Height (With Fire Rating) | Wall Thickness | Fire Rating | Sound Insulation | BS 5234 |       |
| <b>1S15 H<sub>2</sub>O</b><br>   | Studs   | 50mm DIN standard studs @ 600mm centres   | 29                                | 4.15                           | 3              | 75          | 30               | 41      | Heavy |
|   | Facings   | 1 layer 12.5mm Powerpanel H <sub>2</sub> O inner side plus 1 layer 12.5mm Fermacell Board outer side              |                                   |                                |                |             |                  |         |       |
|   | Studs   | 75mm DIN standard studs @ 600mm centres   | 29                                | 4.75                           | 3              | 100         | 30               | 41      | Heavy |
|   | Facings   | 1 layer 12.5mm Powerpanel H <sub>2</sub> O inner side plus 1 layer 12.5mm Fermacell Board outer side              |                                   |                                |                |             |                  |         |       |
|   | Studs   | 100mm DIN standard studs @ 600mm centres  | 29                                | 5.95                           | 3.5            | 125         | 30               | 41      | Heavy |
|   | Facings   | 1 layer 12.5mm Powerpanel H <sub>2</sub> O inner side plus 1 layer 12.5mm Fermacell Board outer side              |                                   |                                |                |             |                  |         |       |
| <b>1S11 H<sub>2</sub>O</b><br>  | Studs   | 75mm DIN standard studs @ 600mm centres   | 30                                | 4.75                           | 4.75           | 100         | 30               | 49      | Heavy |
|   | Facings   | 1 layer 12.5mm Powerpanel H <sub>2</sub> O each side  |                                   |                                |                |             |                  |         |       |
|   | Insulation  | 60mm mineral stone wool density 25kg/m <sup>3</sup>   | 30                                | 5.98                           | 5.98           | 125         | 30               | 49      | Heavy |
|   | Studs   | 100mm DIN standard studs @ 600mm centres  |                                   |                                |                |             |                  |         |       |
|   | Facings   | 1 layer 12.5mm Powerpanel H <sub>2</sub> O each side  | 30                                | 5.98                           | 5.98           | 125         | 30               | 49      | Heavy |
|   | Insulation  | 60mm mineral stone wool density 25kg/m <sup>3</sup>   |                                   |                                |                |             |                  |         |       |
| <b>1S12 H<sub>2</sub>O</b><br> | Studs   | 50mm DIN standard studs @ 600mm centres   | 33                                | 4.15                           | 4.15           | 75          | 30               | 49      | Heavy |
|   | Facings   | 1 layer 12.5mm Powerpanel H <sub>2</sub> O inner side plus 1 layer 12.5mm Fermacell Board outer side              |                                   |                                |                |             |                  |         |       |
|   | Insulation  | 40mm mineral stone wool density 50kg/m <sup>3</sup>   | 33                                | 4.75                           | 4.75           | 100         | 30               | 51      | Heavy |
|   | Studs   | 75mm DIN standard studs @ 600mm centres   |                                   |                                |                |             |                  |         |       |
|   | Facings   | 1 layer 12.5mm Powerpanel H <sub>2</sub> O inner side plus 1 layer 12.5mm Fermacell Board outer side              | 33                                | 5.98                           | 5.98           | 125         | 30               | 51      | Heavy |
|   | Insulation  | 60mm mineral stone wool density 25kg/m <sup>3</sup>   |                                   |                                |                |             |                  |         |       |
| Studs   | 100mm DIN standard studs @ 600mm centres  | 33  | 5.98                              | 5.98                           | 125            | 30          | 51               | Heavy   |       |
| Facings   | 1 layer 12.5mm Powerpanel H <sub>2</sub> O inner side plus 1 layer 12.5mm Fermacell Board outer side              |   |                                   |                                |                |             |                  |         |       |
| Insulation  | 60mm mineral stone wool density 25kg/m <sup>3</sup>   | 33  | 5.98                              | 5.98                           | 125            | 30          | 51               | Heavy   |       |
| Studs   | 100mm DIN standard studs @ 600mm centres  |   |                                   |                                |                |             |                  |         |       |
| <b>1S13 H<sub>2</sub>O</b><br> | Studs   | 50mm DIN standard studs @ 600mm centres   | 48                                | 3.3                            | 3.04           | 85          | 30               | 56      | Heavy |
|   | Facings   | 1 layer 12.5mm Powerpanel H <sub>2</sub> O on inner side plus 1 layer 12.5mm plus 10mm Fermacell Board outer side |                                   |                                |                |             |                  |         |       |
|   | Insulation  | 60mm mineral stone wool density 25kg/m <sup>3</sup>   | 48                                | 4.5                            | 4.5            | 110         | 30               | 56      | Heavy |
|   | Studs   | 75mm DIN standard studs @ 600mm centres   |                                   |                                |                |             |                  |         |       |
|   | Facings   | 1 layer 12.5mm Powerpanel H <sub>2</sub> O on inner side plus 1 layer 12.5mm plus 10mm Fermacell Board outer side | 48                                | 5.32                           | 5.32           | 135         | 30               | 56      | Heavy |
|   | Insulation  | 60mm mineral stone wool density 25kg/m <sup>3</sup>   |                                   |                                |                |             |                  |         |       |
| Studs   | 100mm DIN standard studs @ 600mm centres  | 48  | 5.32                              | 5.32                           | 135            | 30          | 56               | Heavy   |       |
| Facings   | 1 layer 12.5mm Powerpanel H <sub>2</sub> O on inner side plus 1 layer 12.5mm plus 10mm Fermacell Board outer side |   |                                   |                                |                |             |                  |         |       |
| Insulation  | 60mm mineral stone wool density 25kg/m <sup>3</sup>   | 48  | 5.32                              | 5.32                           | 135            | 30          | 56               | Heavy   |       |
| Studs   | 100mm DIN standard studs @ 600mm centres  |   |                                   |                                |                |             |                  |         |       |

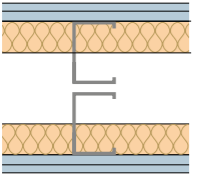
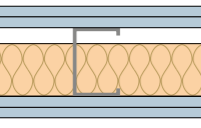
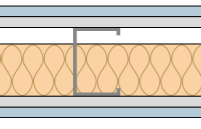
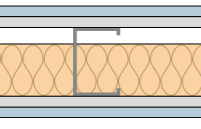
### Fermacell H<sub>2</sub>O PARTITION WALLS ON STEEL STUDS WITH INSULATION

### Fermacell TIMBER WALLS WITH INSULATION – NON LOADBEARING

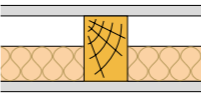
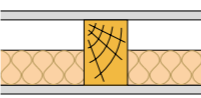
| SYSTEM SPECIFICATIONS   |            |  | Wall Weight       | Wall Height<br>(Without Fire Rating) | Wall Height<br>(With Fire Rating) | Wall Thickness | Fire Rating | Sound Insulation | BS 5234 |
|---|------------|--|-------------------|--------------------------------------|-----------------------------------|----------------|-------------|------------------|---------|
|   |            |  | kg/m <sup>2</sup> | m                                    | m                                 | mm             | mins        | R <sub>w</sub>   | Grade   |
| <b>1S31 H<sub>2</sub>O</b>  |            |  |                   |                                      |                                   |                |             |                  |         |
|    | Studs      | 2 x 50mm DIN standard studs @ 600mm centres  |                   |                                      |                                   |                |             |                  |         |
|   | Facings    | 2 layers 12.5mm Powerpanel H <sub>2</sub> O on both sides  | 64                | 3.5                                  | 3                                 | 155            | 90          | 61               | Heavy   |
|   | Insulation | 2 x 40mm mineral stone wool density 50kg/m <sup>3</sup>  |                   |                                      |                                   |                |             |                  |         |
| <b>1S41 H<sub>2</sub>O</b>  |            |  |                   |                                      |                                   |                |             |                  |         |
|    | Studs      | 75mm DIN standard studs @ 600mm centres  |                   |                                      |                                   |                |             |                  |         |
|   | Facings    | 2 layers 12.5mm Powerpanel H <sub>2</sub> O each side  | 55                | 4                                    | 4                                 | 125            | 120         | 57               | Heavy   |
|   | Insulation | 60mm mineral stone wool density 27kg/m <sup>3</sup>  |                   |                                      |                                   |                |             |                  |         |
|  | Studs      | 100mm @ 600mm centres  |                   |                                      |                                   |                |             |                  |         |
|   | Facings    | 2 layers 12.5mm Powerpanel H <sub>2</sub> O each side  | 55                | 5.85                                 | 5.85                              | 150            | 120         | 57               | Heavy   |
|   | Insulation | 60mm mineral stone wool density 27kg/m <sup>3</sup>  |                   |                                      |                                   |                |             |                  |         |
| <b>1S42 H<sub>2</sub>O</b>  |            |  |                   |                                      |                                   |                |             |                  |         |
|  | Studs      | 75mm DIN standard studs @ 600mm centres  |                   |                                      |                                   |                |             |                  |         |
|   | Facings    | 1 layer 12.5mm Fermacell Board each side plus 1 layer 12.5mm Powerpanel H <sub>2</sub> O each outer side | 60                | 4                                    | 4                                 | 125            | 120         | 60               | Severe  |
|   | Insulation | 60mm mineral stone wool density 27g/m <sup>3</sup>   |                   |                                      |                                   |                |             |                  |         |
|  | Studs      | 100mm @ 600mm centres  |                   |                                      |                                   |                |             |                  |         |
|   | Facings    | 1 layer 12.5mm Fermacell Board each side plus 1 layer 12.5mm Powerpanel H <sub>2</sub> O each outer side | 60                | 5.85                                 | 5.85                              | 150            | 120         | 60               | Severe  |
|   | Insulation | 60mm mineral stone wool density 27kg/m <sup>3</sup>  |                   |                                      |                                   |                |             |                  |         |

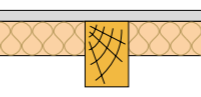
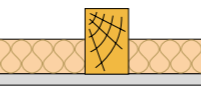
| SYSTEM SPECIFICATIONS   |            |   | Wall Weight       | Wall Height | Wall Thickness | Fire Rating | Sound Insulation | BS 5234 |
|---|------------|---|-------------------|-------------|----------------|-------------|------------------|---------|
|   |            |   | kg/m <sup>2</sup> | m           | mm             | mins        | R <sub>w</sub>   | Grade   |
| <b>1H11</b>   |            |   |                   |             |                |             |                  |         |
|    | Studs      | 89mm x 38mm @ 600mm centres                             |                   |             |                |             |                  |         |
|   | Facings    | 1 layer 12.5mm Fermacell Board each side                | 40                | 4.1         | 114            | 30          | 44               | Severe  |
|   | Insulation | 40mm mineral stone wool density 30kg/m <sup>3</sup>     |                   |             |                |             |                  |         |
| <b>1H12</b>   |            |   |                   |             |                |             |                  |         |
|    | Studs      | 75mm x 50mm @ 500mm centres                             |                   |             |                |             |                  |         |
|   | Facings    | 1 layer 10mm Fermacell Board each side                  | 35                | 4.1         | 95             | 30          | 44               | Heavy   |
|   | Insulation | 40mm mineral stone wool density 30kg/m <sup>3</sup>     |                   |             |                |             |                  |         |
|   | Studs      | 89mm x 38mm @ 500mm centres                             |                   |             |                |             |                  |         |
|   | Facings    | 1 layer 10mm Fermacell Board each side                  | 34                | 4.1         | 109            | 30          | 44               | Heavy   |
|   | Insulation | 40mm mineral stone wool density 30kg/m <sup>3</sup>     |                   |             |                |             |                  |         |
| <b>1H15</b>   |            |   |                   |             |                |             |                  |         |
|  | Studs      | 2 x 50mm x 75mm @ 600mm centres with 30mm air gap       |                   |             |                |             |                  |         |
|   | Facings    | 1 layer 12.5mm Fermacell Board each side                | 41                | 3.1         | 205            | 30          | 57               | Severe  |
|   | Insulation | 2 x 60mm mineral stone wool density 20kg/m <sup>3</sup> |                   |             |                |             |                  |         |
|  | Studs      | 2 x 89mm x 38mm @ 600mm centres with 30mm air gap       |                   |             |                |             |                  |         |
|   | Facings    | 1 layer 12.5mm Fermacell Board each side                | 41                | 3.1         | 233            | 30          | 57               | Severe  |
|   | Insulation | 2 x 60mm mineral stone wool density 20kg/m <sup>3</sup> |                   |             |                |             |                  |         |



### Fermacell TIMBER WALLS WITH INSULATION – NON LOADBEARING

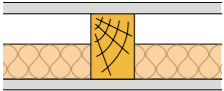
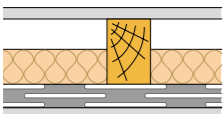
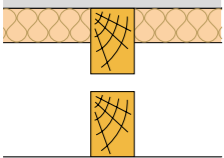
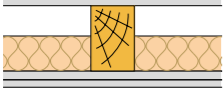

| SYSTEM SPECIFICATIONS   |            |  | Wall Weight       | Wall Height | Wall Thickness | Fire Rating | Sound Insulation | BS 5234 |
|---|------------|--|-------------------|-------------|----------------|-------------|------------------|---------|
|   |            |  | kg/m <sup>2</sup> | m           | mm             | mins        | R <sub>w</sub>   | Grade   |
| <b>1H22</b>   |            |  |                   |             |                |             |                  |         |
|    | Studs      | 75mm x 50mm @ 600mm centres  |                   |             |                |             |                  |         |
|   | Facings    | 1 layer 12.5mm Fermacell Board each side   | 40                | 4.1         | 100            | 60          | 44               | Severe  |
|   | Insulation | 40mm mineral stone wool density 45kg/m <sup>3</sup> or 60mm mineral stone wool density 30kg/m <sup>3</sup> |                   |             |                |             |                  |         |
|   | Studs      | 89mm x 38mm @ 600mm centres  |                   |             |                |             |                  |         |
|   | Facings    | 1 layer 12.5mm Fermacell Board each side   | 41                | 4.1         | 114            | 60          | 44               | Severe  |
|   | Insulation | 70mm mineral stone wool density 35kg/m <sup>3</sup>  |                   |             |                |             |                  |         |
| <b>1H22RB</b>   |            |  |                   |             |                |             |                  |         |
|    | Studs      | 75mm x 50mm @ 600mm centres  |                   |             |                |             |                  |         |
|   | Facings    | 1 layer 12.5mm Fermacell Board each side   | 40                | 4.1         | 116            | 60          | 50               | Severe  |
|   | Insulation | 40mm mineral stone wool density 45kg/m <sup>3</sup> or 60mm mineral stone wool density 30kg/m <sup>3</sup> |                   |             |                |             |                  |         |
|   | Studs      | 89mm x 38mm @ 600mm centres  |                   |             |                |             |                  |         |
| Resilient Bar to inner side   | Facings    | 1 layer 12.5mm Fermacell Board each side   | 41                | 4.1         | 130            | 60          | 50               | Severe  |
|   | Insulation | 70mm mineral stone wool density 35kg/m <sup>3</sup>  |                   |             |                |             |                  |         |
| <b>1H23</b>   |            |  |                   |             |                |             |                  |         |
|  | Studs      | 2 x 75mm x 50mm @ 600mm centres with 30mm air gap  | 43                | 3.1         | 205            | 60          | 57               | Severe  |
|   | Facings    | 1 layer 12.5mm Fermacell Board each side   |                   |             |                |             |                  |         |
|   | Insulation | 70mm mineral stone wool density 30kg/m <sup>3</sup>  |                   |             |                |             |                  |         |
|   | Studs      | 2 x 89mm x 38mm @ 600mm centres with 30mm air gap  |                   |             |                |             |                  |         |
|   | Facings    | 1 layer 12.5mm Fermacell Board each side   | 43                | 3.1         | 233            | 60          | 57               | Severe  |
|   | Insulation | 70mm mineral stone wool density 35kg/m <sup>3</sup>  |                   |             |                |             |                  |         |
| <b>1H29</b>   |            |  |                   |             |                |             |                  |         |
|  | Studs      | 75mm x 50mm @ 600mm centres  |                   |             |                |             |                  |         |
|   | Facings    | 1 layer 12.5mm Fermacell Board each side plus 1 layer 10mm Fermacell Board outer side                      | 53                | 4.1         | 110            | 60          | 51               | Severe  |
|   | Insulation | 70mm mineral stone wool density 30kg/m <sup>3</sup>  |                   |             |                |             |                  |         |
|   | Studs      | 89mm x 38mm @ 600mm centres  |                   |             |                |             |                  |         |
|   | Facings    | 1 layer 12.5mm Fermacell Board each side plus 1 layer 10mm Fermacell Board outer side                      | 53                | 4.1         | 124            | 60          | 51               | Severe  |
|   | Insulation | 70mm mineral stone wool density 35kg/m <sup>3</sup>  |                   |             |                |             |                  |         |

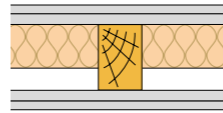
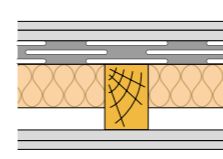
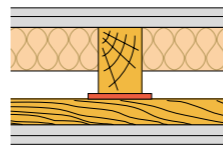

### Fermacell TIMBER WALLS WITH INSULATION – NON LOADBEARING

| SYSTEM SPECIFICATIONS   |            |  | Wall Weight       | Wall Height | Wall Thickness | Fire Rating | Sound Insulation | BS 5234 |
|---|------------|--|-------------------|-------------|----------------|-------------|------------------|---------|
|   |            |  | kg/m <sup>2</sup> | m           | mm             | mins        | R <sub>w</sub>   | Grade   |
| <b>1H31</b>   |            |  |                   |             |                |             |                  |         |
|    | Studs      | 75mm x 50mm @ 600mm centres  |                   |             |                |             |                  |         |
|   | Facings    | 1 layer 12.5mm Fermacell Board each side plus 1 layer 10mm Fermacell Board each outer side   | 64                | 4.1         | 120            | 90          | 54               | Severe  |
|   | Insulation | 70mm mineral stone wool density 30kg/m <sup>3</sup>  |                   |             |                |             |                  |         |
|   | Studs      | 89mm x 38mm @ 600mm centres  |                   |             |                |             |                  |         |
|   | Facings    | 1 layer 12.5mm Fermacell Board each side plus 1 layer 10mm Fermacell Board each outer side   | 64                | 4.1         | 134            | 90          | 54               | Severe  |
|   | Insulation | 70mm mineral stone wool density 35kg/m <sup>3</sup>  |                   |             |                |             |                  |         |
| <b>1H31RB</b>   |            |  |                   |             |                |             |                  |         |
|   | Studs      | 75mm x 50mm @ 600mm centres  |                   |             |                |             |                  |         |
|   | Facings    | 1 layer 12.5mm Fermacell Board each side plus 1 layer 10mm Fermacell Board each outer side   | 64                | 4.1         | 136            | 90          | 58               | Severe  |
|   | Insulation | 70mm mineral stone wool density 30kg/m <sup>3</sup>  |                   |             |                |             |                  |         |
|   | Studs      | 89mm x 38mm @ 600mm centres  |                   |             |                |             |                  |         |
| Resilient Bar to inner side   | Facings    | 1 layer 12.5mm Fermacell Board each side plus 1 layer 10mm Fermacell Board each outer side   | 64                | 4.1         | 155            | 90          | 58               | Severe  |
|   | Insulation | 70mm mineral stone wool density 35kg/m <sup>3</sup>  |                   |             |                |             |                  |         |
| <b>1H32</b>   |            |  |                   |             |                |             |                  |         |
|  | Studs      | 75mm x 50 @ 600mm centres (one-sided traverse 30/50 timber without mineral stone wool strip) |                   |             |                |             |                  |         |
|   | Facings    | 1 layer 12.5mm Fermacell Board each side plus 1 layer 10mm Fermacell Board each outer side   | 65                | 4.1         | 150            | 90          | 54               | Severe  |
|   | Insulation | 50mm mineral stone wool density 50kg/m <sup>3</sup>  |                   |             |                |             |                  |         |
|   | Studs      | 75mm x 50mm @ 600mm centres (one-sided traverse 30/50 timber with mineral stone wool strip)  |                   |             |                |             |                  |         |
|   | Facings    | 1 layer 12.5mm Fermacell Board each side plus 1 layer 10mm Fermacell Board each outer side   | 65                | 4.1         | 150            | 90          | 57               | Severe  |
|   | Insulation | 50mm mineral stone wool density 50kg/m <sup>3</sup>  |                   |             |                |             |                  |         |

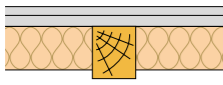
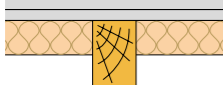
### Fermacell TIMBER WALLS WITH INSULATION – NON LOADBEARING

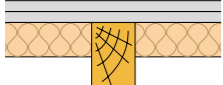
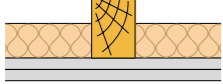
### Fermacell TIMBER WALLS WITHOUT INSULATION – NON LOADBEARING

| SYSTEM SPECIFICATIONS   |            | kg/m <sup>2</sup>  | m           | mm             | mins        | R <sub>w</sub>   | Grade   |
|---|------------|--|-------------|----------------|-------------|------------------|---------|
|   |            | Wall Weight  | Wall Height | Wall Thickness | Fire Rating | Sound Insulation | BS 5234 |
| <b>1H35</b>   |            |  |             |                |             |                  |         |
|    | Studs      | 2 x 75mm x 50mm @ 500mm centres with 10mm air gap  |             |                |             |                  |         |
|   | Facings    | 1 layer 12.5mm Fermacell Board each side plus 1 layer 10mm Fermacell Board each outer side |             |                |             |                  |         |
|   | Insulation | 50mm mineral stone wool density 50kg/m <sup>3</sup>  |             |                |             |                  |         |
|   | Studs      | 2 x 89mm x 38mm @ 500mm centres with 10mm air gap  |             |                |             |                  |         |
|   | Facings    | 1 layer 12.5mm Fermacell Board each side plus 1 layer 10mm Fermacell Board each outer side |             |                |             |                  |         |
|   | Insulation | 50mm mineral stone wool density 50kg/m <sup>3</sup>  |             |                |             |                  |         |
|   |            | 69   | 4.1         | 205            | 90          | 66               | Severe  |
|   |            | 70   | 4.1         | 233            | 90          | 66               | Severe  |
| <b>1H36</b>   |            |  |             |                |             |                  |         |
|    | Studs      | 2 x 75mm x 50mm @ 500mm centres with 30mm air gap  |             |                |             |                  |         |
|   | Facings    | 2 layers 10mm Fermacell Board each side  |             |                |             |                  |         |
|   | Insulation | 2 x 60mm mineral stone wool density 20kg/m <sup>3</sup>                                    |             |                |             |                  |         |
|   | Studs      | 2 x 50mm x 100mm @ 600mm centres with 30mm air gap   |             |                |             |                  |         |
|   | Facings    | 2 layers 12.5mm Fermacell Board each side  |             |                |             |                  |         |
|   | Insulation | 2 x 60mm mineral stone wool density 20kg/m <sup>3</sup>                                    |             |                |             |                  |         |
|   | Studs      | 2 x 89mm x 38mm @ 500mm centres with 90mm air gap  |             |                |             |                  |         |
|   | Facings    | 2 layers 10mm Fermacell Board each side  |             |                |             |                  |         |
|   | Insulation | 2 x 60mm mineral stone wool density 20kg/m <sup>3</sup>                                    |             |                |             |                  |         |
|   |            | 41   | 4.1         | 280            | 60          | 62               | Severe  |
|   |            | 41   | 4.1         | 290            | 60          | 64               | Severe  |
|   |            | 41   | 3.1         | 233            | 60          | 64               | Severe  |
|   |            | * 9mm Sheathing Board or 10mm Fermacell Board  |             |                |             |                  |         |
| <b>1H37</b>   |            |  |             |                |             |                  |         |
|  | Studs      | 2 x 75mm x 50mm @ 500mm centres with 90mm air gap  |             |                |             |                  |         |
|   | Facings    | 2 layers 10mm Fermacell Board each side  |             |                |             |                  |         |
|   | Insulation | 2 x 60mm mineral stone wool density 20kg/m <sup>3</sup>                                    |             |                |             |                  |         |
|  |            | * Robust Detail compliant with 240mm gap between inner faces of boards                     |             |                |             |                  |         |
|   |            | 41   | 4.1         | 230            | 60          | 64               | Severe  |

| SYSTEM SPECIFICATIONS   |         | kg/m <sup>2</sup>   | m           | mm             | mins        | R <sub>w</sub>   | Grade   |
|---|---------|---|-------------|----------------|-------------|------------------|---------|
|   |         | Wall Weight   | Wall Height | Wall Thickness | Fire Rating | Sound Insulation | BS 5234 |
| <b>1H13</b>   |         |   |             |                |             |                  |         |
|  | Studs   | 75mm x 50mm @ 600mm centres   |             |                |             |                  |         |
|   | Facings | 1 layer 12.5mm Fermacell Board each side  |             |                |             |                  |         |
|   | Studs   | 89mm x 38mm @ 600mm centres   |             |                |             |                  |         |
|   | Facings | 1 layer 12.5mm Fermacell Board each side  |             |                |             |                  |         |
|   | Studs   | 75mm x 50mm @ 600mm centres   |             |                |             |                  |         |
|   | Facings | 1 layer 15mm Fermacell Board each side  |             |                |             |                  |         |
|   |         | 40  | 4.1         | 100            | 30          | 41               | Severe  |
|   |         | 40  | 4.1         | 114            | 30          | 41               | Severe  |
|   |         | 46  | 4.1         | 100            | 60          | 41               | Severe  |
| <b>1H21</b>   |         |   |             |                |             |                  |         |
|  | Studs   | 75mm x 50mm @ 500mm centres   |             |                |             |                  |         |
|   | Facings | 2 layers 10mm Fermacell Board each side   |             |                |             |                  |         |
|   | Studs   | 75mm x 50mm @ 600mm centres   |             |                |             |                  |         |
|   | Facings | 1 layer 12.5mm Fermacell Board each side plus 1 layer 10mm Fermacell Board each outer side  |             |                |             |                  |         |
|   | Studs   | 89mm x 38mm @ 500mm centres   |             |                |             |                  |         |
|   | Facings | 2 layers 10mm Fermacell Board each side   |             |                |             |                  |         |
|   | Studs   | 89mm x 38mm @ 600mm centres   |             |                |             |                  |         |
|   | Facings | 1 layer 12.5mm Fermacell Board each side plus 1 layer 10mm Fermacell Board each outer side  |             |                |             |                  |         |
|   |         | 61  | 4.1         | 115            | 60          | 48               | Severe  |
|   |         | 67  | 4.1         | 120            | 60          | 51               | Severe  |
|   |         | 61  | 4.1         | 129            | 60          | 48               | Severe  |
|   |         | 67  | 4.1         | 134            | 60          | 51               | Severe  |
|   |         | Similar performance is achievable by using 40mm x 60mm studs, and 40mm x 80mm studs with the same boarding and insulation configurations. Contact the Technical Department for further details. |             |                |             |                  |         |

Fermacell TIMBER WALLS – H<sub>2</sub>O – NON LOADBEARING

| SYSTEM SPECIFICATIONS   |            | kg/m <sup>2</sup>  | m                                 | m                              | mm             | mins        | R <sub>w</sub>   | Grade   |       |
|---|------------|--|-----------------------------------|--------------------------------|----------------|-------------|------------------|---------|-------|
|   |            | Wall Weight  | Wall Height (Without Fire Rating) | Wall Height (With Fire Rating) | Wall Thickness | Fire Rating | Sound Insulation | BS 5234 |       |
| <b>1H21 H<sub>2</sub>O</b>  |            |  |                                   |                                |                |             |                  |         |       |
|  | Studs      | 60mm x 40mm @ 600mm centres  |                                   |                                |                |             |                  |         |       |
|   | Facings    | 1 layer 12.5mm Fermacell Powerpanel H <sub>2</sub> O Board each side | 33                                | 3.1                            | 3.1            | 85          | 60               | 42      | Heavy |
|   | Insulation | 60mm mineral stone wool density 25kg/m <sup>3</sup>                  |                                   |                                |                |             |                  |         |       |
|   | Studs      | 75mm x 50mm @ 600mm centres  |                                   |                                |                |             |                  |         |       |
|   | Facings    | 1 layer 12.5mm Fermacell Powerpanel H <sub>2</sub> O Board each side | 35                                | 4.1                            | 4.1            | 100         | 60               | 42      | Heavy |
|   | Insulation | 60mm mineral stone wool density 25kg/m <sup>3</sup>                  |                                   |                                |                |             |                  |         |       |
|   | Studs      | 89mm x 38mm @ 600mm centres  |                                   |                                |                |             |                  |         |       |
|   | Facings    | 1 layer 12.5mm Fermacell Powerpanel H <sub>2</sub> O Board each side | 36                                | 4.1                            | 4.1            | 114         | 60               | 42      | Heavy |
|   | Insulation | 60mm mineral stone wool density 25kg/m <sup>3</sup>                  |                                   |                                |                |             |                  |         |       |

Fermacell TIMBER WALLS WITHOUT INSULATION - LOADBEARING

|   |         |  |      |    |     |     |    |    |        |
|---|---------|--|------|----|-----|-----|----|----|--------|
| <b>1HT14</b>  |         |  |      |    |     |     |    |    |        |
|  | Studs   | 89mm x 38mm @ 600mm centres              |      |    |     |     |    |    |        |
|   | Facings | 1 layer 12.5mm Fermacell Board each side | 5.56 | 35 | 2.6 | 114 | 30 | 41 | Severe |
| <b>1HT15</b>  |         |  |      |    |     |     |    |    |        |
|  | Studs   | 89mm x 38mm @ 600mm centres              |      |    |     |     |    |    |        |
|   | Facings | 1 layer 15mm Fermacell Board each side   | 5.56 | 39 | 2.6 | 119 | 30 | 41 | Severe |

Fermacell TIMBER WALLS WITHOUT INSULATION – LOADBEARING

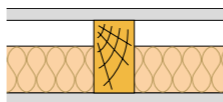
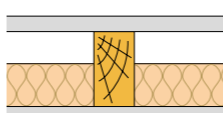
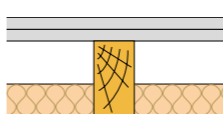
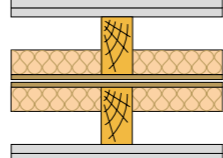
| SYSTEM SPECIFICATIONS   |            | kN/stud   | kg/m <sup>2</sup> | m           | mm             | mins        | R <sub>w</sub>     | Grade   |        |
|---|------------|---|-------------------|-------------|----------------|-------------|--------------------|---------|--------|
|   |            | Applied Load  | Wall Weight       | Wall Height | Wall Thickness | Fire Rating | Sound Insulation   | BS 5234 |        |
| <b>1HT11</b>  |            |   |                   |             |                |             |                    |         |        |
|    | Studs      | 89mm x 38mm @ 600mm centres   |                   |             |                |             |                    |         |        |
|   | Facings    | 1 layer 12.5mm Fermacell Board each side  | 5.56              | 41          | 2.6            | 114         | 30                 | 44      | Severe |
|   | Insulation | 90mm mineral glass wool density 10kg/m <sup>3</sup> or 40mm mineral stone wool density 30kg/m <sup>3</sup>  |                   |             |                |             |                    |         |        |
| <b>1HT22</b>  |            |   |                   |             |                |             |                    |         |        |
|    | Studs      | 89mm x 38mm @ 600mm centres   |                   |             |                |             |                    |         |        |
|   | Facings    | 1 layer 18mm Fermacell Board each side  | A                 | 58          | 3              | 125         | 60                 | 44      | Severe |
|   | Insulation | 90mm mineral stone wool density 30kg/m <sup>3</sup>   |                   |             |                |             |                    |         |        |
|   | Studs      | 120mm x 45mm @ 600mm centres  |                   |             |                |             |                    |         |        |
|   | Facings    | 1 layer 15mm Fermacell Board each side  | 10.8              | 48          | 3              | 150         | 60                 | 44      | Severe |
|   | Insulation | 120mm mineral stone wool density 30kg/m <sup>3</sup>  |                   |             |                |             |                    |         |        |
|   | Studs      | 140mm x 38mm @ 600mm centres  |                   |             |                |             |                    |         |        |
|   | Facings    | 1 layer 15mm Fermacell Board each side  | 10                | 48          | 3              | 150         | 60                 | 44      | Severe |
|   | Insulation | 140mm mineral stone wool density 30kg/m <sup>3</sup>  |                   |             |                |             |                    |         |        |
| <b>1HT23</b>  |            |   |                   |             |                |             |                    |         |        |
|  | Studs      | 89mm x 38mm @ 600mm centres   |                   |             |                |             |                    |         |        |
|   | Facings    | 2 layers 12.5mm Fermacell Board inner side plus 1 layer 12.5mm Fermacell Board outer side   | 5.56              | 56          | 2.6            | 127         | 60/30 <sup>†</sup> | 44      | Severe |
|   | Insulation | 90mm mineral glass wool density 10kg/m <sup>3</sup>   |                   |             |                |             |                    |         |        |
| <b>1HT23 – Twin Wall</b>  |            |   |                   |             |                |             |                    |         |        |
|  | Studs      | 2 x 89mm x 38mm @ 600mm centres   |                   |             |                |             |                    |         |        |
|   | Facings    | 2 layers 12.5mm Fermacell Board inner side plus 2 layers 12.5mm Fermacell Board outer side. Inner cavity single layer may be timber based product. Refer to Fermacell technical information | 5.56              | 112         | 2.6            | 270         | 60                 | ≥66     | Severe |
|   | Insulation | 2 x 90mm mineral glass wool density 10kg/m <sup>3</sup>   |                   |             |                |             |                    |         |        |

\* 9mm Sheathing Board or 10mm fermacell board

A – Loading up to maximum for timber grade stress in accordance with EN 1995-1-1 and EN 1995-1-2

N.B. Refer to the Fermacell Technical Department for board fixing option.

+ = Fire rating from Fermacell side only.

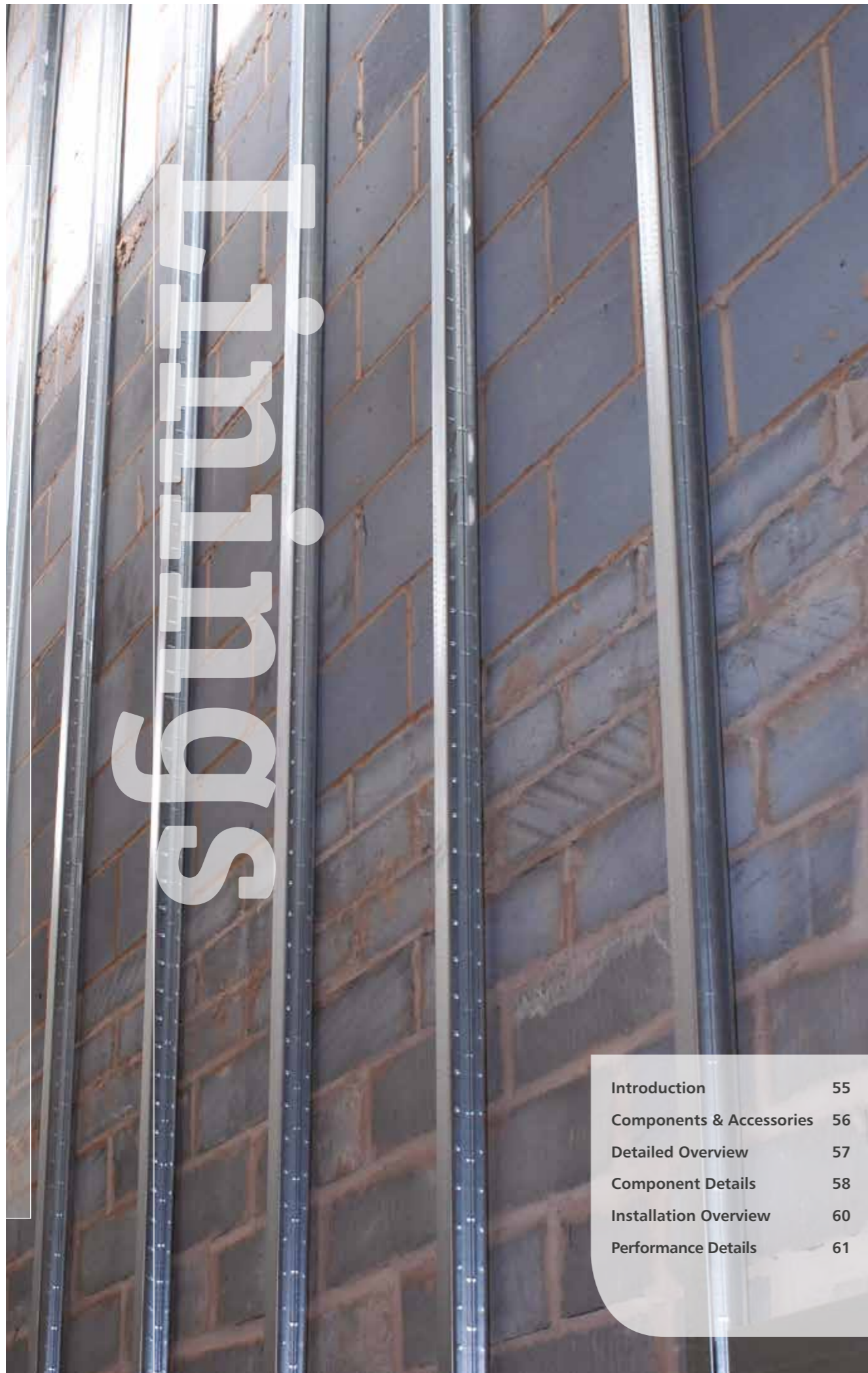

|                          |    |
|--------------------------|----|
| Introduction             | 55 |
| Components & Accessories | 56 |
| Detailed Overview        | 57 |
| Component Details        | 58 |
| Installation Overview    | 60 |
| Performance Details      | 61 |

| MARKET SECTORS |               |
|----------------|---------------|
| ▶              | Refurbishment |
| ▶              | Academic      |
| ▶              | Residential   |
| ▶              | Healthcare    |
| ▶              | Recreation    |
| ▶              | Industrial    |

| PERFORMANCE RATINGS |         |
|---------------------|---------|
| ▶                   | 20 dB   |
| ▶                   | 60 dB   |
| ▶                   | 30 mins |
| ▶                   | 60 mins |

- Fermacell PERFORMANCE**
- ▶ **Impact** – Able to withstand impact from people as well as objects (door handles etc).
  - ▶ **Acoustics** – Enhanced acoustic insulation providing simple solutions to upgrade existing walls.
  - ▶ **Ease of construction** – A variety of Shaftwall and variable cavity lining systems allowing simple, cost effective solutions for refurbishment projects eliminating wet trades.
  - ▶ **Environmental** – Fermacell boards are manufactured from recycled content and are recyclable. Decreasing the carbon footprint and increasing the BREEAM rating of the building.

**Fermacell is perfectly suited for wall lining solutions, from lining of proprietary metal systems to traditional timber frame as well as dot and dab fixing.**

**METAL FRAME LINING SYSTEMS**

The use of Fermacell with metal frame Dry Lining systems allows a dry system to be installed for lining walls where the background may be unsuitable for “dabbing”, where the existing wall may be out of true or the surface may not allow the adhesion of the Fermacell Bonding Compound.

Metal frame systems allow the system to be fixed directly to the existing wall allowing different cavity widths to be accommodated. This can be as little as 15mm with a metal furring system. Insulation and vapour barriers can be installed behind the Fermacell boards. Where possible place the insulation between the battens and the wall where there is a narrow cavity otherwise this will reduce its overall effectiveness and may cause cold bridging. We recommend that thermal calculations are undertaken to eliminate cold bridging issues.

**TIMBER BATTENS**

Fermacell may be fixed to timber battens of a minimum size of 50mm x 30mm using 30mm Fermacell screws or Galvanised staples. The use of battens adds little to the lining thickness and provides a service cavity.

Where greater level of thermal insulation are required insulation boards may be sandwiched between the battens and the wall. If possible place the insulation between the battens and the wall otherwise this will reduce its overall effectiveness and may cause cold bridging.

### DIRECT BOND & ADJUSTABLE WALL LININGS

### LINING SYSTEM CONSTRUCTION

#### COMPONENTS

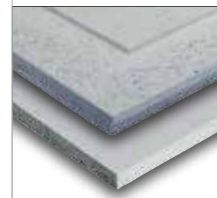

**Fermacell Board**  
Fermacell Square edge or Tapered edge.

**Thickness** 10mm, 12.5mm, 15mm and 18mm

**Sizes** 1200 x 1000mm to 1200 x 3000mm



**Fermacell Fine Surface Treatment**  
For giving Fermacell boards a smooth finish prior to painting.

**Coverage** 4-5m<sup>2</sup> per ltr

**Pack Size** 3ltr or 10ltr



**Fermacell Joint Filler**  
For filling 5-7mm gaps between boards & stopping screw heads.

**Coverage** 5m<sup>2</sup> per kg for filling Tapered edge joints. 10m<sup>2</sup> for finishing glue joints and screw heads.

**Pack Size** 5kg or 20kg



**Fermacell Jointstik**  
For edge glueing square edged Fermacell boards.

**Coverage** 20 lm / 310ml tube

**Pack Size** 310ml tubes



**30/40/55mm Fermacell Screws**  
For fixing Fermacell boards to steel and timber subframes.

**Coverage** 13 screws per m<sup>2</sup> for walls (for each side)  
30 screws per m<sup>2</sup> for ceilings

**Pack Size** Box of 250 screws or box of 1000 screws



**Fermacell Bonding Compound**  
For dot & dabbing Tapered edge Fermacell boards.

**Coverage** 3-4kg/m<sup>2</sup>

**Pack Size** 20kg bag



**Fermacell Mesh Jointing Tape**  
Mesh tape used to reinforce Tapered edge joints.

**Pack Size** 45 mtr roll



**Fermacell Paper Jointing Tape**  
Paper tape used to reinforce Tapered edge joints.

**Pack Size** 75 mtr roll

#### ACCESSORIES



**Fermacell Board Knife**  
For scoring and snapping Fermacell boards.



**Fermacell Spatula**  
For applying Fine Surface Treatment.

**Size** 250mm



**DIN standard metal lining - e.g fermacell**

**Size** Nominal 0.6 gauge 50mm fixing face

NB: For direct bond fixing method use Tapered Edge Fermacell Boards.

Compound at 400-600mm depending on board size

**NB: Apply bonding to board not to the wall**

Fermacell Bonding Compound continuous 50mm from edge

Fermacell Bonding Compound

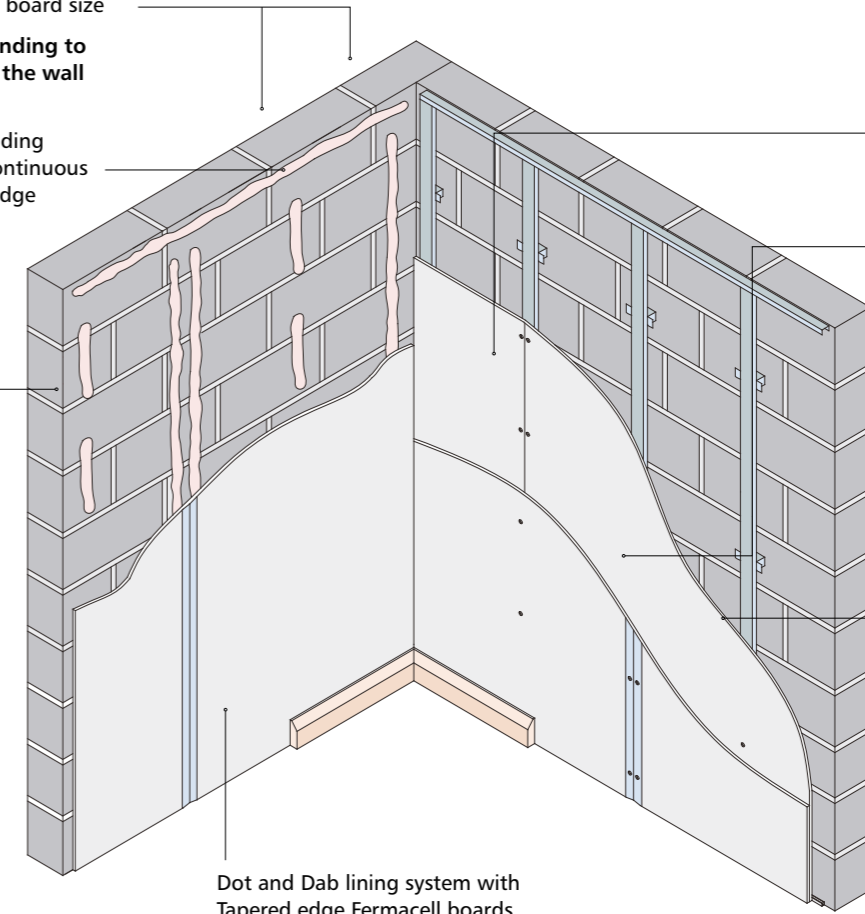

Fermacell Screws @ 250mm c/c (12.5mm board)

Board edges glued with Fermacell Jointstik or taped and jointed with Fermacell Tape and Joint Filler, dependent on board type used

Metal Furring Lining system mechanically fixed as required or DIN standard independent lining

Dot and Dab lining system with Tapered edge Fermacell boards

With Dot and dab fixing, Fermacell recommends two mechanical fixings once bonding has set. Advisable where greater loads are to be fixed directly to the boards.

For installation data please refer to the Fermacell Handy Guide.

**NB: Apply bonding compound to boards, not to supporting surface. Illustration above shows final positions of dabs once board is fitted.**

### INDEPENDENT & ADJUSTABLE WALL LININGS

#### LININGS

##### (1) Independent Wall Lining

Independent wall linings can be constructed by using DIN standard C Stud sections

- Allow a minimum cavity of 10mm; a vapour control barrier should be installed as required
- Fix the bottom track allowing for the desired cavity at 600mm centres using proprietary fixings. Plumb the ceiling line track in to position and fix
- Cut the DIN standard studs 5mm shorter than the floor – ceiling height and position at the recommended centres for the board width
- Insulation can be inserted either between the studs or in the cavity providing there is adequate clearance to the existing substrate
- Install the board as per fixing instructions in the Fixing and Finishing section

\* For double layer systems the second layer can be screw fixed or stapled into place – please contact our technical department for staple fixing details.

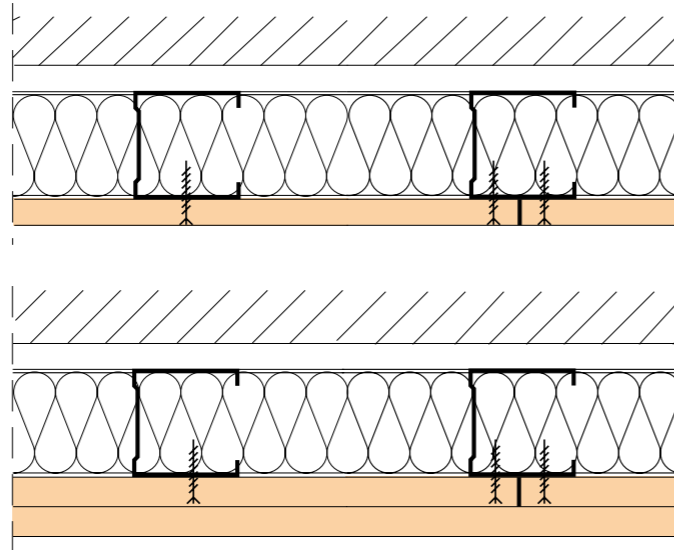

#### LININGS

##### (2) Adjustable cavity steel lining systems

Variable cavity width from 30 – 125mm can be achieved by using DIN standard Lining systems.

- Mark horizontal lines at 800mm centres and 600mm vertical centres on the existing wall
- Fix the bottom track allowing for the desired cavity at 600mm centres using proprietary fixings. Plumb the ceiling line track and fix
- Install the adjustable brackets fixing directly to the wall using proprietary fixings at the intersections of the setting out lines
- Cut the adjustable channels 5mm shorter than the floor – ceiling height and position inline with the brackets. Fix the brackets to the channels, bend back excess
- Install the board as per fixing instructions in the Fixing and Finishing section

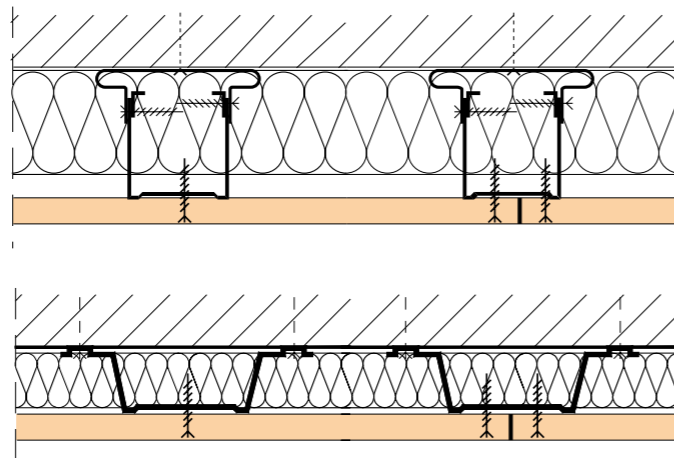

### DIRECT BOND & INDEPENDENT WALL LININGS

#### LININGS

##### (3) Timber lining systems

- Allow a minimum cavity of 50mm and a breather membrane to BS 4016 should be installed for timber frame constructions
- Construct the timber lining as required
- Insulation can be inserted either between the studs or in the cavity allowing adequate clearance to the existing substrate
- Install the board as per fixing instructions in the Fixing and Finishing section. Fermacell boards can be screw fixed or stapled in to place – please contact our technical department for staple fixing details

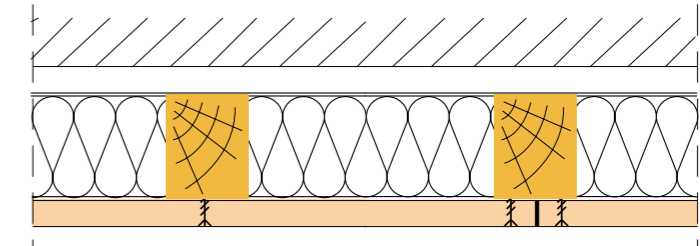

#### DOT & DAB

##### (4) Dot and Dab (Direct Bond)

- Ensure the masonry background is dry and dust free
- Direct bonding is not recommended for solid exterior walls prone to moisture ingress, an adjustable or independent lining system should be used instead
- The minimum finished dab thickness should be no less than 10mm and not greater than 25mm
- Apply Fermacell Bonding Compound dabs at 400mm or 600mm centres vertically to suit the board width
- Each dab should be 50-75mm wide x 250mm long and 25mm in from the board edge at 30mm vertical centres
- A continuous ribbon of Fermacell Bonding Compound should be applied around the perimeter of the board where they are to be fitted to external walls and around door/window frames and sockets
- The contact area of the dabs should be at least 20% of the board surface

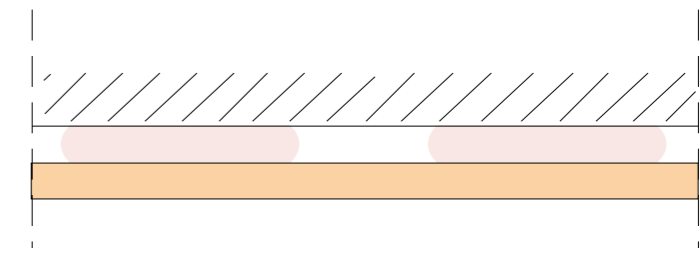

**NB: Bonding compound should be applied to the board, not to the supporting background. Contact Technical Services for assistance.**

### WALL LININGS

### FERMACELL INDEPENDENT WALL LININGS – STEEL

#### STEP ONE



Ensure the floor is clean and flat; mark out the line of the wall lining allowing for the width of the Fermacell boards and any desired cavity. If using an adjustable cavity metal system mark out the bracket centres along the channel paths.

Plumb the ceiling line with the floor track and mark out. Fix the base and ceiling tracks at 600mm centres using suitable fixings and insert DIN standard studs into the tracks. If using an adjustable cavity system, fit the brackets and then secure the channels to them.

#### STEP TWO



Insert any desired insulation whilst maintaining a cavity from the background, cut the Fermacell boards 10mm less than the room height and install, leaving gaps as required for jointing to the ceiling.

#### STEP THREE



Screw fix the boards at maximum 250mm centres using Fermacell screws. When direct bonding using a traditional dot & dab method, the use of Tapered edge boards is recommended. NB: Apply dabs to boards.

#### STEP FOUR



Square edge boards: Apply Fermacell Jointstik to the board edge, tightly butt the next board and screw fix. Tapered edge board: Position and fix the next board. Once bonding is dry, apply Fermacell Joint filler, embedding a reinforcement tape, and strike off flush with the taper area.

#### STEP FIVE



After a minimum of 8 hours remove the excess Jointstik and fill the screw heads, sand the Joint Filler for Tapered edge boards once dry.

#### STEP SIX



For both Square edge and Taper Edge boards apply Fermacell Fine Surface Treatment to the entire surface for a smooth finish prior to painting. See installation manual for other finishing options.

| Wall Weight       | Wall Height | Wall Thickness | Fire Rating | Improved Sound Insulation | BS 5234 |
|-------------------|-------------|----------------|-------------|---------------------------|---------|
| kg/m <sup>2</sup> | m           | mm             | mins        | ΔR <sub>w</sub>           | Grade   |

#### SYSTEM SPECIFICATIONS

##### 3S01

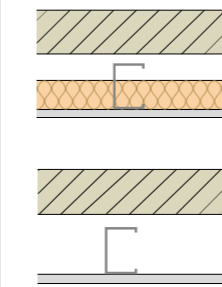

| Studs                                    | Facings                                 | Insulation | Wall Weight | Wall Height | Wall Thickness | Fire Rating | Improved Sound Insulation | BS 5234 |
|--|---|------------|-------------|-------------|----------------|-------------|---------------------------|---------|
| 50mm DIN standard studs @ 600mm centres  | 1 layer 12.5mm Fermacell Board one side | Optional   | 20          | 3           | 62.5           | N/A         | N/A                       | Heavy   |
| 75mm DIN standard studs @ 600mm centres  | 1 layer 12.5mm Fermacell Board one side | Optional   | 20          | 4           | 87.5           | N/A         | N/A                       | Severe  |
| 100mm DIN standard studs @ 600mm centres | 1 layer 12.5mm Fermacell Board one side | Optional   | 20          | 4.25        | 112.5          | N/A         | N/A                       | Severe  |

##### 3S12

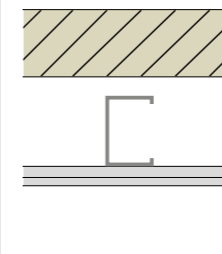

| Studs                                    | Facings   | Insulation | Wall Weight | Wall Height | Wall Thickness | Fire Rating     | Improved Sound Insulation | BS 5234 |
|--|---|------------|-------------|-------------|----------------|-----------------|---------------------------|---------|
| 50mm DIN standard studs @ 600mm centres  | 1 layer 12.5mm Fermacell Board plus 1 layer 10mm Fermacell Board one side |            | 32          | 3           | 72.5           | 30 <sup>†</sup> | N/A                       | Heavy*  |
| 75mm DIN standard studs @ 600mm centres  | 1 layer 12.5mm Fermacell Board plus 1 layer 10mm Fermacell Board one side |            | 32          | 3.5         | 97.5           | 30 <sup>†</sup> | N/A                       | Severe  |
| 100mm DIN standard studs @ 600mm centres | 1 layer 12.5mm Fermacell Board plus 1 layer 10mm Fermacell Board one side |            | 32          | 4.5         | 122.5          | 30 <sup>†</sup> | N/A                       | Severe  |

##### 3S21

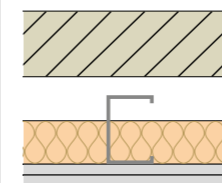

| Studs                                    | Facings                                  | Insulation  | Wall Weight | Wall Height | Wall Thickness | Fire Rating     | Improved Sound Insulation | BS 5234 |
|--|--|---|-------------|-------------|----------------|-----------------|---------------------------|---------|
| 50mm DIN standard studs @ 600mm centres  | 2 layers 12.5mm Fermacell Board one side | 50mm mineral stone wool density 38kg/m <sup>3</sup> | 41          | 3           | 75             | 60 <sup>†</sup> | 22                        | Heavy*  |
| 75mm DIN standard studs @ 600mm centres  | 2 layers 12.5mm Fermacell Board one side | 50mm mineral stone wool density 38kg/m <sup>3</sup> | 41          | 3.5         | 100            | 60 <sup>†</sup> | 22                        | Severe  |
| 100mm DIN standard studs @ 600mm centres | 2 layers 12.5mm Fermacell Board one side | 50mm mineral stone wool density 38kg/m <sup>3</sup> | 41          | 4           | 125            | 60 <sup>†</sup> | 22                        | Severe  |

\* - Interpolated Performance

†Classification from both sides

### Fermacell INDEPENDENT WALL LININGS – STEEL

### Fermacell INDEPENDENT WALL LININGS – STEEL WITH POWERPANEL H<sub>2</sub>O

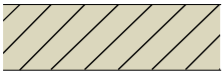
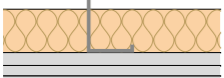

| SYSTEM SPECIFICATIONS   |            | kg/m <sup>2</sup>                        | m   | mm  | mins            | ΔR <sub>w</sub> | Grade   |
|---|------------|--|-----|-----|-----------------|-----------------|---------|
| <b>3S31</b>   |            |  |     |     |                 |                 |         |
|  | Studs      | 50mm DIN standard studs @ 600mm centres  |     |     |                 |                 |         |
|   | Facings    | 53                                       | 3.5 | 90  | 90 <sup>+</sup> | ≥22             | Severe* |
|   | Insulation |  |     |     |                 |                 |         |
|  | Studs      | 75mm DIN standard studs @ 600mm centres  |     |     |                 |                 |         |
|   | Facings    | 53                                       | 4   | 115 | 90 <sup>+</sup> | ≥22             | Severe  |
|   | Insulation |  |     |     |                 |                 |         |
|   | Studs      | 100mm DIN standard studs @ 600mm centres |     |     |                 |                 |         |
|   | Facings    | 53                                       | 4.5 | 140 | 90 <sup>+</sup> | ≥22             | Severe  |
|   | Insulation |  |     |     |                 |                 |         |
|   | Studs      | 125mm DIN standard studs @ 600mm centres |     |     |                 |                 |         |
|   | Facings    | 53                                       | 5   | 165 | 90 <sup>+</sup> | ≥22             | Severe  |
|   | Insulation |  |     |     |                 |                 |         |

\* - Interpolated Performance

### DIRECT BOND

| SYSTEM SPECIFICATIONS   |   | kg/m <sup>2</sup>                                    | mm | m <sup>2</sup><br>k/W |
|---|---|--|----|-----------------------|
| <b>3TP01</b>  |   |  |    |                       |
|  | Facings   | 1 layer 10mm Tapered Edge Fermacell Board one side   |    |                       |
|   | Facings   | 1 layer 12.5mm Tapered Edge Fermacell Board one side |    |                       |
|   | NB: Apply bonding compound to boards, not to the supporting background. |  |    |                       |

\*Classification from both sides

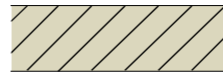
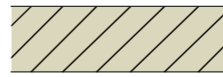
| SYSTEM SPECIFICATIONS   |            | kg/m <sup>2</sup>                       | m    | mm   | mins            | ΔR <sub>w</sub> | Grade   |
|---|------------|---|------|------|-----------------|-----------------|---------|
| <b>3S01 H<sub>2</sub>O</b>  |            |   |      |      |                 |                 |         |
|    | Studs      | 50mm DIN standard studs @ 600mm centres |      |      |                 |                 |         |
|   | Facings    | 19                                      | 2.45 | 62.5 | N/A             | N/A             | Heavy*  |
|   | Insulation |   |      |      |                 |                 |         |
|    | Studs      | 75mm @ 600mm centres                    |      |      |                 |                 |         |
|   | Facings    | 19                                      | 3.7  | 87.5 | N/A             | N/A             | Heavy*  |
|   | Insulation |   |      |      |                 |                 |         |
| <b>3S02 H<sub>2</sub>O</b>  |            |   |      |      |                 |                 |         |
|    | Studs      | 75mm DIN standard studs @ 600mm centres |      |      |                 |                 |         |
|   | Facings    | 32                                      | 3.9  | 100  | N/A             | N/A             | Heavy*  |
|   | Insulation |   |      |      |                 |                 |         |
| <b>3S11 H<sub>2</sub>O</b>  |            |   |      |      |                 |                 |         |
|  | Studs      | 75mm DIN standard studs @ 600mm centres |      |      |                 |                 |         |
|   | Facings    | 37                                      | 3    | 100  | 30 <sup>+</sup> | 21              | Severe* |
|   | Insulation |   |      |      |                 |                 |         |







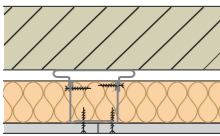

\* - Interpolated Performance

\*Classification from both sides

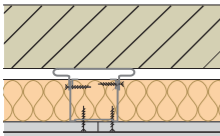
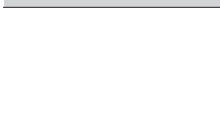

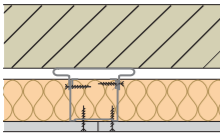

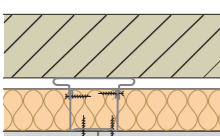

### Fermacell VARIABLE CAVITY WALL LININGS

### Fermacell WALL LINING ON TIMBER

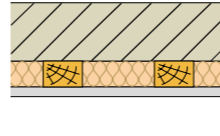
| SYSTEM SPECIFICATIONS   |               |   | kg/m <sup>2</sup> | m           | mm             | R <sub>w</sub>             | k <sup>2</sup> /kW | Grade   |
|---|---------------|---|-------------------|-------------|----------------|----------------------------|--------------------|---------|
|   |               |   | Wall Weight       | Wall Height | Wall Thickness | Flanking Sound Performance | Thermal Resistance | BS 5234 |
| <b>3WS01</b>  |               |   |                   |             |                |                            |                    |         |
|    | DIN Std Studs | Wall Liner System @ 600mm centres                         |                   |             |                |                            |                    |         |
|   | Facings       | 1 layer 12.5mm Fermacell Board one side                   | 17                | 8           | ≥42            | 57                         | 0.53               | Severe  |
|   | Insulation    | 20mm mineral stone wool density 20kg/m <sup>3</sup>       |                   |             |                |                            |                    |         |
|    | DIN Std Studs | Wall Liner System @ 600mm centres                         |                   |             |                |                            |                    |         |
|   | Facings       | 1 layer 12.5mm Fermacell Board one side                   | 20                | 8           | 62.5           | 57                         | 1.28               | Severe  |
|   | Insulation    | 50mm mineral stone wool density 20kg/m <sup>3</sup>       |                   |             |                |                            |                    |         |
|    | DIN Std Studs | Wall Liner System @ 600mm centres                         |                   |             |                |                            |                    |         |
|   | Facings       | 1 layer 12.5mm Fermacell Board one side                   | 20                | 8           | 87.5           | 57                         | 1.28               | Severe  |
|   | Insulation    | 50mm mineral stone wool density 20kg/m <sup>3</sup>       |                   |             |                |                            |                    |         |
| <b>3WS02</b>  |               |   |                   |             |                |                            |                    |         |
|  | DIN Std Studs | Wall Liner System @ 600mm centres                         |                   |             |                |                            |                    |         |
|   | Facings       | 2 layers 12.5mm Fermacell Board one side                  | 32                | 8           | ≥55            | 62                         | 0.57               | Severe  |
|   | Insulation    | 20mm mineral stone wool density 20kg/m <sup>3</sup>       |                   |             |                |                            |                    |         |
|  | DIN Std Studs | Wall Liner System @ 600mm centres                         |                   |             |                |                            |                    |         |
|   | Facings       | 2 layers 12.5mm Fermacell Board one side                  | 35                | 8           | 75             | 62                         | 1.31               | Severe  |
|   | Insulation    | 50mm mineral stone wool density 20kg/m <sup>3</sup>       |                   |             |                |                            |                    |         |
|  | DIN Std Studs | Wall Liner System @ 600mm centres                         |                   |             |                |                            |                    |         |
|   | Facings       | 2 layers 12.5mm Fermacell Board one side                  | 35                | 8           | 100            | 62                         | 1.31               | Severe  |
|   | Insulation    | 50mm mineral stone wool density 20kg/m <sup>3</sup>       |                   |             |                |                            |                    |         |
| <b>3WS11</b>  |               |   |                   |             |                |                            |                    |         |
|  | DIN Std Studs | Wall Liner System @ 600mm centres                         |                   |             |                |                            |                    |         |
|   | Facings       | 1 layer 12.5mm Fermacell Board one side                   | 17                | 8           | ≥62.5          | 57                         | 1.31               | Severe  |
|   | Insulation    | 50mm mineral stone wool density 40kg/m <sup>3</sup>       |                   |             |                |                            |                    |         |
|  | DIN Std Studs | Wall Liner System @ 600mm centres                         |                   |             |                |                            |                    |         |
|   | Facings       | 1 layer 12.5mm Fermacell Board one side                   | 20                | 8           | 62.5           | 57                         | 1.31               | Severe  |
|   | Insulation    | 50mm mineral stone wool density 40kg/m <sup>3</sup>       |                   |             |                |                            |                    |         |
| <b>3WS12</b>  |               |   |                   |             |                |                            |                    |         |
|  | DIN Std Studs | Wall Liner System 50mm DIN standard studs @ 600mm centres |                   |             |                |                            |                    |         |
|   | Facings       | 2 layers 12.5mm Fermacell Board one side                  | 32                | 8           | ≥75            | 62                         | 1.31               | Severe  |
|   | Insulation    | 50mm mineral stone wool density 40kg/m <sup>3</sup>       |                   |             |                |                            |                    |         |
|  | DIN Std Studs | Wall Liner System @ 600mm centres                         |                   |             |                |                            |                    |         |
|   | Facings       | 2 layers 12.5mm Fermacell Board one side                  | 35                | 8           | 75             | 62                         | 1.31               | Severe  |
|   | Insulation    | 50mm mineral stone wool density 40kg/m <sup>3</sup>       |                   |             |                |                            |                    |         |

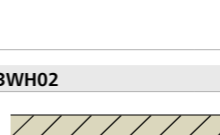
For installation details please refer to the Fermacell Handy Guide.

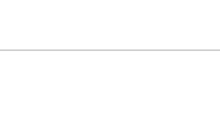
| SYSTEM SPECIFICATIONS   |            |   | kg/m <sup>2</sup> | m           | mm             | R <sub>w</sub>             | k <sup>2</sup> /kW | Grade   |
|---|------------|---|-------------------|-------------|----------------|----------------------------|--------------------|---------|
|   |            |   | Wall Weight       | Wall Height | Wall Thickness | Flanking Sound Performance | Thermal Resistance | BS 5234 |
| <b>3WH01</b>  |            |   |                   |             |                |                            |                    |         |
|    | Battens    | 30mm x 50mm @ 600mm centres   |                   |             |                |                            |                    |         |
|   | Facings    | 1 layer 12.5mm Fermacell Board one side                                   | 16                | 8           | 42.5           | 59                         | 0.78               | Severe  |
|   | Insulation | 30mm mineral stone wool density 20kg/m <sup>3</sup>                       |                   |             |                |                            |                    |         |
|    | Battens    | 40mm x 50mm @ 600mm centres   |                   |             |                |                            |                    |         |
|   | Facings    | 1 layer 12.5mm Fermacell Board one side                                   | 16                | 8           | 52.5           | 59                         | 1.03               | Severe  |
|   | Insulation | 40mm mineral stone wool density 20kg/m <sup>3</sup>                       |                   |             |                |                            |                    |         |
|    | Battens    | 60mm x 40mm @ 600mm centres   |                   |             |                |                            |                    |         |
|   | Facings    | 1 layer 12.5mm Fermacell Board one side                                   | 17                | 8           | 72.5           | 59                         | 1.53               | Severe  |
|   | Insulation | 60mm mineral stone wool density 20kg/m <sup>3</sup>                       |                   |             |                |                            |                    |         |
| <b>3WH02</b>  |            |   |                   |             |                |                            |                    |         |
|  | Battens    | 30mm x 50mm @ 600mm centres   |                   |             |                |                            |                    |         |
|   | Facings    | 1 layer 12.5mm Fermacell Board plus 1 layer 10mm Fermacell Board one side | 26                | 8           | 52.5           | 63                         | 0.81               | Severe  |
|   | Insulation | 30mm mineral stone wool density 20kg/m <sup>3</sup>                       |                   |             |                |                            |                    |         |
|  | Battens    | 40mm x 50mm @ 600mm centres   |                   |             |                |                            |                    |         |
|   | Facings    | 1 layer 12.5mm Fermacell Board plus 1 layer 10mm Fermacell Board one side | 26                | 8           | 62.5           | 63                         | 1.06               | Severe  |
|   | Insulation | 40mm mineral stone wool density 20kg/m <sup>3</sup>                       |                   |             |                |                            |                    |         |
|  | Battens    | 60mm x 40mm @ 600mm centres   |                   |             |                |                            |                    |         |
|   | Facings    | 1 layer 12.5mm Fermacell Board plus 1 layer 10mm Fermacell Board one side | 27                | 8           | 82.5           | 63                         | 1.56               | Severe  |
|   | Insulation | 60mm mineral stone wool density 20kg/m <sup>3</sup>                       |                   |             |                |                            |                    |         |

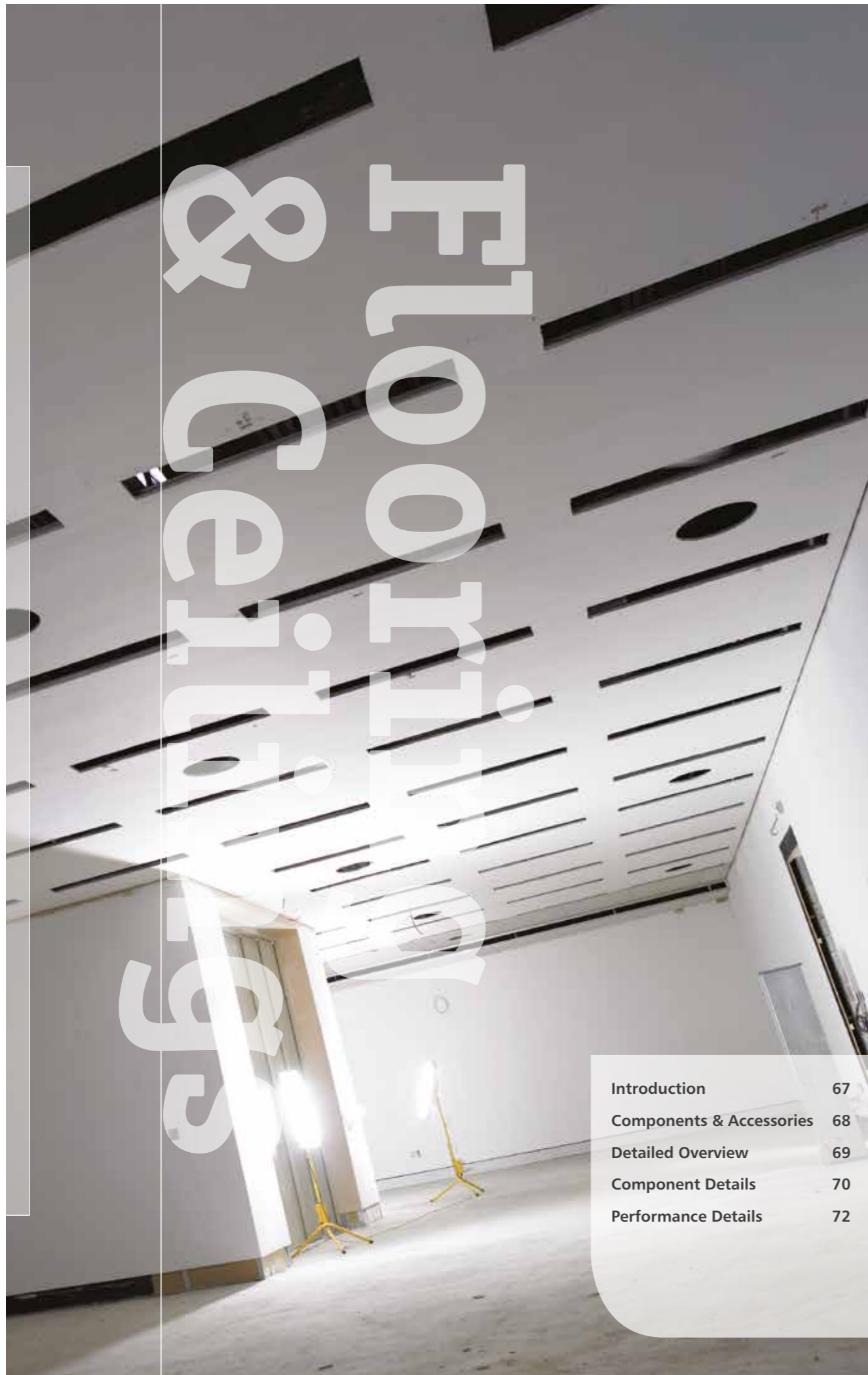

|                          |    |
|--------------------------|----|
| Introduction             | 67 |
| Components & Accessories | 68 |
| Detailed Overview        | 69 |
| Component Details        | 70 |
| Performance Details      | 72 |

| MARKET SECTORS |                          |
|----------------|--------------------------|
| ➤              | Residential & Self build |
| ➤              | Refurbishment            |
| ➤              | Healthcare               |
| ➤              | Education                |
| ➤              | Timber Frame             |

| PERFORMANCE RATINGS |         |         |
|---------------------|---------|---------|
| 🔊                   | 17 dB   | 69 dB   |
| 🔥                   | 30 mins | 90 mins |

- Fermacell PERFORMANCE**
- Impact sound insulation – Fermacell flooring systems offer a variety of cost effective, simple to install solutions for improving the acoustic insulation of solid masonry floors and timber floor constructions.
  - Airborne sound insulation – The use of Fermacell with resilient or suspended ceiling systems to the underside of the joists will greatly enhance the airborne acoustic performance.
  - Fire protection – Using the floor elements along with our ceiling systems provide superior fire protection from above and below the structure.
  - Speed of installation – The Fermacell dry flooring systems allows a dry screed to be laid on uneven floors and heating systems, eliminating drying times and reducing installation time and cost.
  - Environmental – Fermacell boards are manufactured from recycled content and are recyclable, decreasing the carbon footprint and increasing the BREEAM rating of the building.





**Using Fermacell Flooring and Ceiling systems provide simple solutions to acoustic and fire requirements.**





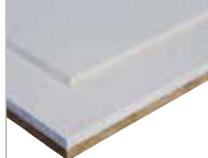

The flooring systems offer a dry screed system solution which provides impact acoustic performance for refurbishment as well as new build and timber frame.

The range of systems we produce not only increase sound insulation but also give a dry screed solution to overlay underfloor heating and levelling solutions to uneven floors.

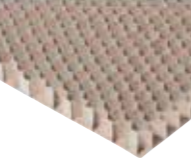
Fermacell’s ceiling systems provide superior acoustic and fire performance to timber and concrete ceilings by using either a resilient bar or a suspended ceiling system, decreasing the airborne acoustic transmission.

### FLOORING ELEMENTS

| COMPONENTS  |  |
|---|--|
|    | <p><b>Fermacell Flooring Element</b><br/>For screeding and insulating floors.</p> <p><b>Pack Size</b> 20mm, 25mm, 30mm, 40mm, 45mm and 50mm</p> <p><b>Coverage</b> 1500mm x 500mm per sheet</p>              |
|    | <p><b>Fermacell Floor Glue</b><br/>For bonding floor elements.</p> <p><b>Pack Size</b> 1kg bottle</p> <p><b>Coverage</b> 25m – 28m<sup>2</sup>/bottle</p>  |
|    | <p><b>Fermacell Joint Filler</b><br/>For stopping screw heads.</p> <p><b>Pack Size</b> 5kg or 20kg</p> <p><b>Coverage</b> 10m<sup>2</sup> per kg for fine finishing glue joints and stopping screw heads</p> |
|  | <p><b>19mm or 22mm Fermacell Floor Screws</b><br/>For securing flooring elements.</p> <p><b>Pack Size</b> 1000 or 250</p> <p><b>Coverage</b> 15 per m<sup>2</sup></p>  |
|  | <p><b>30mm, 50mm, 100mm Fermacell Perimeter Strip</b><br/>To reduce flanking transmission between flooring and walls.</p> <p><b>Pack Size</b> 60 lm for 30mm and 50mm depth<br/>30 lm for 100mm depth</p>    |
|  | <p><b>Fermacell Dry Levelling Compound</b><br/>To level uneven floors 10mm – 60mm.</p> <p><b>Pack Size</b> 50ltr bag</p> <p><b>Coverage</b> 5m<sup>2</sup>/bag @ 10mm thick</p>                              |
|  | <p><b>Fermacell Trickle Protection Sheet</b><br/>For use under Fermacell Dry Levelling Compound.</p> <p><b>Pack Size</b> 1.5m x 50m Roll</p> <p><b>Coverage</b> 75m<sup>2</sup></p>                          |

| COMPONENTS  |  |
|---|--|
|    | <p><b>30mm, 60mm Fermacell Honeycomb sheets</b><br/><b>1500mm x 1000mm</b><br/>A retaining sheet for honeycombing infill.</p> <p><b>Pack Size</b> 30mm – 30 sheets, 60mm – 15 sheets</p> <p><b>Coverage</b> 1.5m<sup>2</sup> per sheet</p>           |
|    | <p><b>Honeycomb Infill</b><br/>Mass providing infill for honeycomb sheets.</p> <p><b>Pack Size</b> 22.5kg bag/48 per pallet</p> <p><b>Coverage</b> 2 bags per m<sup>2</sup> for 30mm infill</p>  |
|   | <p><b>Fermacell Bonded Levelling Compound</b><br/>Cement base levelling compound for levelling from 40mm to 2000mm.</p> <p><b>Pack Size</b> 80 ltr bag (22kg) /16 per pallet</p> <p><b>Coverage</b> 10 litres/m<sup>2</sup> per 10mm of leveling</p> |
|  | <p><b>Fermacell Self Levelling Compound</b><br/>To level uneven floors.</p> <p><b>Pack Size</b> 50 ltr bag/ 25kg</p> <p><b>Coverage</b> 15m<sup>2</sup> per 1mm thickness</p>  |
|  | <p><b>Fermacell Levelling Set</b><br/>For levelling dry flooring compound.</p> <p><b>Pack Size</b> Each 15kg</p>   |
|  | <p><b>Fermacell H<sub>2</sub>O Flooring Element 25mm</b><br/>For use in wet areas.</p> <p><b>Pack Size</b> 60 per pack</p> <p><b>Coverage</b> 1250mm x 500mm per sheet</p>   |
|  | <p><b>23mm Fermacell H<sub>2</sub>O Flooring Screws</b><br/>For fixing H<sub>2</sub>O flooring elements.</p> <p><b>Pack Size</b> 500</p> <p><b>Coverage</b> 20 screws per m<sup>2</sup></p>  |

### TIMBER JOIST/FLOOR CONSTRUCTION

#### FERMACELL FLOORING SOLUTIONS

Fermacell's flooring solutions are designed for use as floating floors in a wide variety of applications. Manufactured from Fermacell Gypsum Fibreboards, they give a dry, robust and simple solution to your flooring requirements.

Used in conjunction with Fermacell to the ceiling, the flooring elements give a wide variety of solutions as a complete floor/ceiling specification.

There are five main areas of use for Fermacell flooring, and the constructions vary slightly according to the specific application. All the systems share the same basic technology which produces a continuous floating membrane capable of installation and use in 24 hours, and which is ready to accept a wide range of floor finishes.

1. Improving acoustic insulation: Types 2E31
2. Over floor heating: Types 2E22 & 2E11
3. Levelling uneven floors: A range of solutions from 0 – 2000mm are available.
4. Improving thermal insulation: Types 2E13 & 2E14
5. Wet-room floors: TE Powerpanel H<sub>2</sub>O Flooring element.

#### FERMACELL CEILING SOLUTIONS

Fermacell's ceiling solutions give simple solutions to timber, steel and concrete floors by providing acoustic, fire, thermal mass and fixing performance. Due to the nature of the Fermacell, Robust details can be easily achieved as 2 layers of 10mm board to the ceiling, giving the minimum mass requirement. This mass is used in multiple layers in thermal mass applications giving a fast dry solution.

Due to the screw holding ability, simple fittings can be screwed directly into the ceiling board, or where greater loads are required, specialist fittings can be used. Please see table opposite, or contact our Technical Department for more details on **+44 (0) 121 311 3480**.

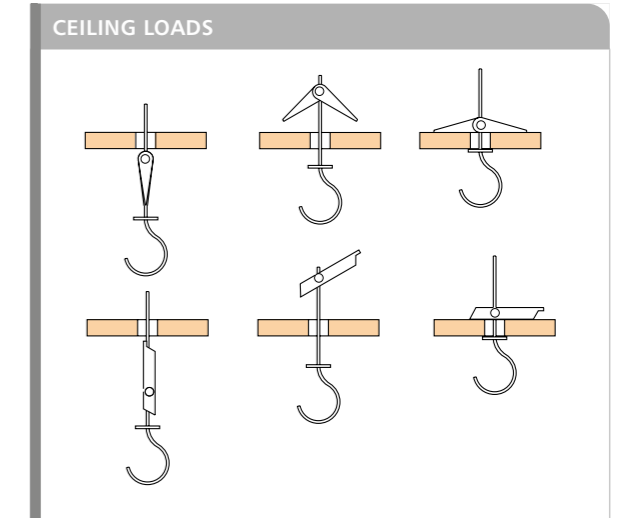

| Maximum allowable load in kg <sup>(1)</sup> per Fermacell Board thickness inmm <sup>(2)</sup> |                   |
|---|-------------------|
| Fermacell Board thickness (mm)  | kg <sup>(3)</sup> |
| 10mm  | 20                |
| 12.5mm  | 22                |
| 15mm  | 23                |
| 10 + 10mm   | 24                |
| 12.5 + 12.5mm   | 25                |
| 12.5mm H <sub>2</sub> O   | 20                |

- (1) Tested to DIN 4103, safety factor 2.
- (2) Support spacing of the sub-structure ≤ 35 x board thickness. Board fixed to the sub-structure with Fermacell screws.
- (3) Observe the manufacturers operating and installation instructions.

Where additional loads are to be applied then the loading capability of the sub-structure should be checked.

### MF CEILING CONSTRUCTION

Recommended Maximum Ceiling Loadings

| Metal angle suspension centres | Primary Channel Centres | Maximum loading inc board kg/m <sup>2</sup> |
|--------------------------------|-------------------------|---|
| 1200                           | 600                     | 74  |
| 1200                           | 900                     | 50  |
| 1200                           | 1200                    | 35  |

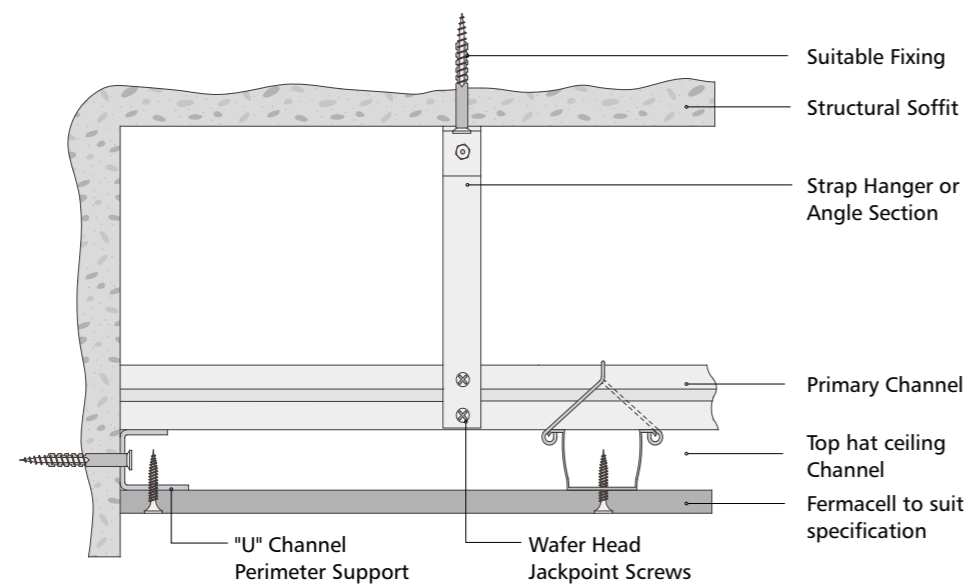
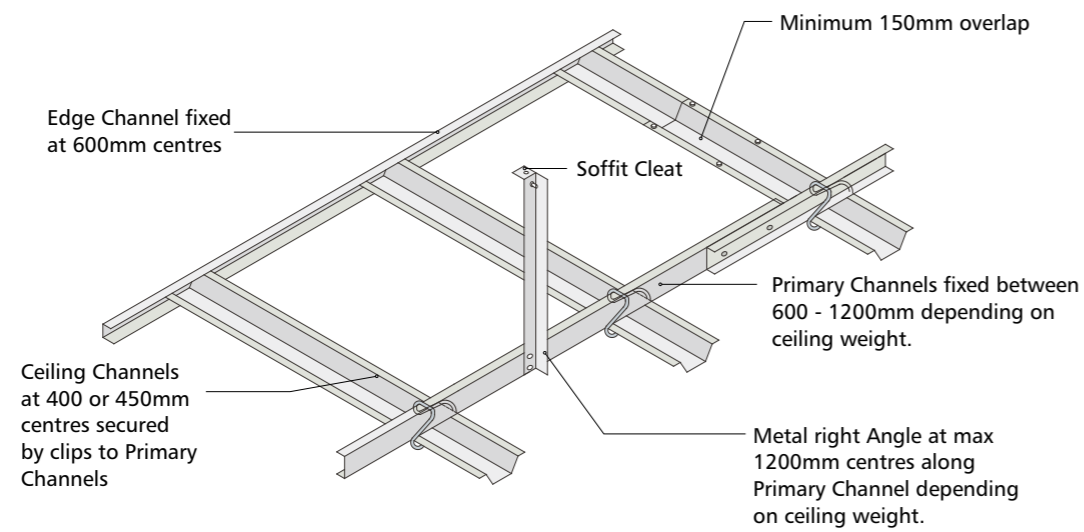

Note: Where ceiling weight exceeds 20kg/m<sup>2</sup> use Wafer Head Self Drilling Screws in lieu of Connecting Clips. It is recommended that all double board systems are screw fixed. 25mm flat strap may be used on ceiling drops up to 1 metre deep.

### FLOORING & CEILING CONSTRUCTIONS

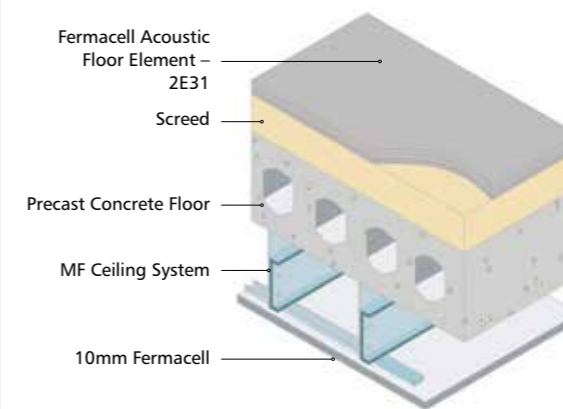
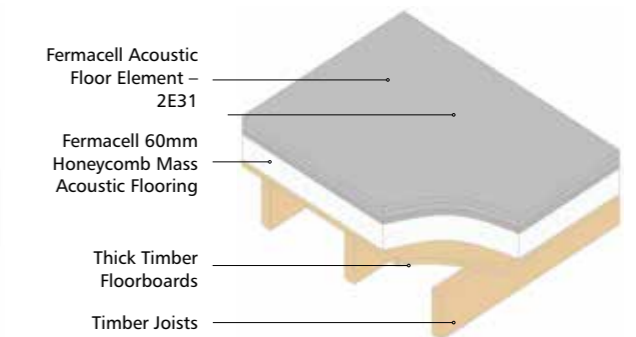
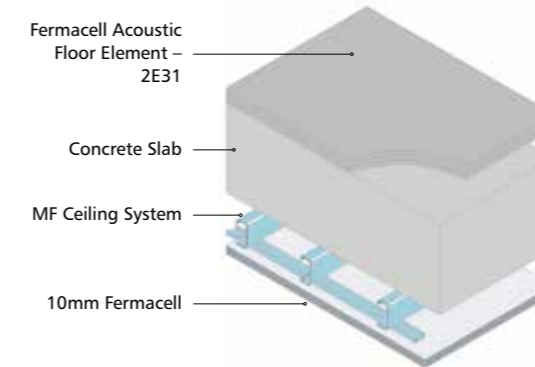
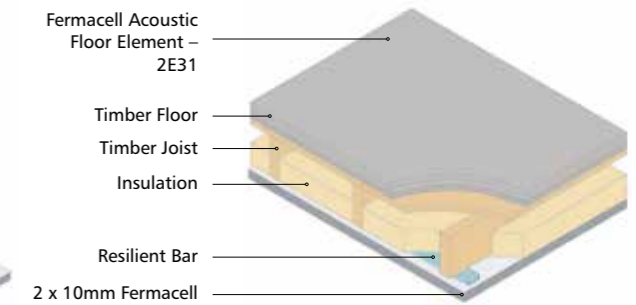
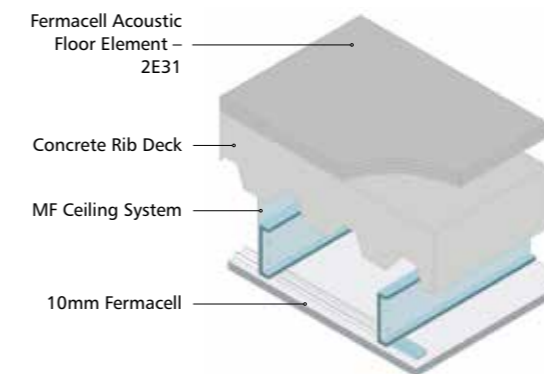

## Fermacell CEILINGS IN STEEL AND TIMBER SUBSTRUCTURES

Ceiling performance irrespective of structure above.

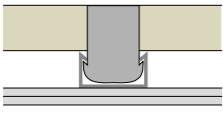
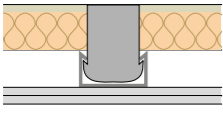
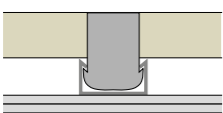
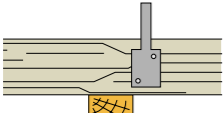
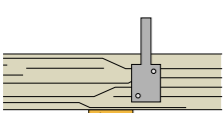
| SYSTEM SPECIFICATIONS   |            |  |  | Ceiling Weight    | Construction Height | Fire Rating |
|---|------------|--|--|-------------------|---------------------|-------------|
|   |            |  |  | kg/m <sup>2</sup> | mm                  | mins        |
| <b>2S11↑U</b>   |            |  |  |                   |                     |             |
|    | Channels   | 60mm x 0.6 @ max 350mm centres   |  | 27                | 75                  | 30          |
|   | Facings    | 2 layers 10mm Fermacell Board one side   |  |                   |                     |             |
|   | Type       | Suspended steel ceiling system with fire protection from below. Min 0.6 gauge. Confirm hanging and layout first              |  |                   |                     |             |
|   | Channels   | 60mm x 0.6 @ max 350mm centres   |  | 33                | 80                  | 30          |
|   | Facings    | 2 layers 12.5mm Fermacell Board one side   |  |                   |                     |             |
|   | Type       | Suspended steel ceiling system with fire protection from below. Min 0.6 gauge. Confirm hanging and layout first              |  |                   |                     |             |
| <b>2S11↑U↓O</b>   |            |  |  |                   |                     |             |
|    | Channels   | 60mm x 0.6 @ max 350mm centres   |  | 28                | 130                 | 30          |
|   | Facings    | 2 layers 10mm Fermacell Board one side   |  |                   |                     |             |
|   | Insulation | 40mm mineral stone wool density 30kg/m <sup>3</sup>  |  |                   |                     |             |
|   | Type       | Suspended steel ceiling system with fire protection from above and below. Min 0.6 gauge. Confirm hanging and layout first    |  |                   |                     |             |
|   | Channels   | 60mm x 0.6 @ max 350mm centres   |  | 35                | 135                 | 30          |
|   | Facings    | 2 layers 12.5mm Fermacell Board one side   |  |                   |                     |             |
|   | Insulation | 40mm mineral stone wool density 30kg/m <sup>3</sup>  |  |                   |                     |             |
|   | Type       | Suspended steel ceiling system with fire protection from above and below. Min 0.6 gauge. Confirm hanging and layout first    |  |                   |                     |             |
| <b>2S21↑U</b>   |            |  |  |                   |                     |             |
|  | Channels   | 60mm x 0.6 @ max 350mm centres   |  | 39                | 85                  | 60*         |
|   | Facings    | 1 x 18mm + 1 x 15mm Fermacell Board to one side  |  |                   |                     |             |
|   | Insulation | None   |  |                   |                     |             |
|   | Type       | Suspended steel ceiling system with fire protection from below. Min 0.6 gauge. Confirm hanging and layout first              |  |                   |                     |             |
| <b>2H13↑U</b>   |            |  |  |                   |                     |             |
|  | Battens    | Min primary timber size 60mm x 40mm and min batten size 24mm x 48mm at max 350mm centres. Confirm support layout as required |  |                   |                     |             |
|   | Facings    | 2 layers 10mm Fermacell Board one side   |  | 28                | 85                  | 30*         |
|   | Insulation | None   |  |                   |                     |             |
|   | Type       | Suspended timber ceiling system with fire protection from below  |  |                   |                     |             |
|   | Battens    | Min primary timber size 60mm x 40mm and min batten size 24mm x 48mm at max 350mm centres. Confirm support layout as required |  |                   |                     |             |
|   | Facings    | 2 layers 12.5mm Fermacell Board one side   |  | 37                | 90                  | 30*         |
|   | Insulation | None   |  |                   |                     |             |
|   | Type       | Suspended timber ceiling system with fire protection from below  |  |                   |                     |             |
| <b>2H23↑U</b>   |            |  |  |                   |                     |             |
|  | Battens    | Min primary timber size 60mm x 40mm and min batten size 24mm x 48mm at max 350mm centres. Confirm support layout as required |  |                   |                     |             |
|   | Facings    | 1 x 18mm + 1 x 15mm Fermacell Board to one side only   |  | 46                | 95                  | 60*         |
|   | Insulation | None   |  |                   |                     |             |
|   | Type       | Suspended timber ceiling system with fire protection from below  |  |                   |                     |             |

\*To DIN Assessment GA 3368/618/14 MPA BS. N.B. This is a German assessment, for a BS solution please contact the Technical Department.

## Fermacell CEILINGS IN STEEL AND TIMBER SUBSTRUCTURES

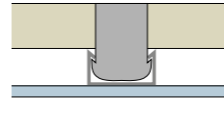
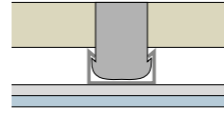
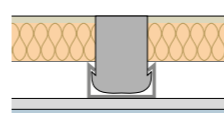
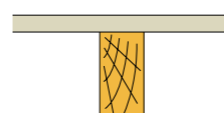
| SYSTEM SPECIFICATIONS   |            |   |  | Ceiling Weight    | Construction Depth | Fire Rating |
|---|------------|---|--|-------------------|--------------------|-------------|
|   |            |   |  | kg/m <sup>2</sup> | mm                 | mins        |
| <b>2S01 H<sub>2</sub>O</b>  |            |   |  |                   |                    |             |
|    | Channels   | 60mm x 0.6 @ max 500mm centres  |  | 16                | 70                 | N/A         |
|   | Facings    | 1 layer 12.5mm Powerpanel H <sub>2</sub> O one side   |  |                   |                    |             |
|   | Insulation | None  |  |                   |                    |             |
|   | Type       | Suspended steel ceiling system with fire protection from below. Min 0.6 gauge. Confirm hanging and layout first           |  |                   |                    |             |
| <b>2S11 H<sub>2</sub>O↑U</b>  |            |   |  |                   |                    |             |
|    | Channels   | 60mm x 0.6 @ max 500mm centres  |  | 32                | 80                 | 30          |
|   | Facings    | 1 layer 12.5mm Fermacell Board plus 1 layer 12.5mm Powerpanel H <sub>2</sub> O one side                                   |  |                   |                    |             |
|   | Insulation | None  |  |                   |                    |             |
|   | Type       | Suspended steel ceiling system with fire protection from below. Min 0.6 gauge. Confirm hanging and layout first           |  |                   |                    |             |
| <b>2S11 H<sub>2</sub>O↑U↓O</b>  |            |   |  |                   |                    |             |
|   | Channels   | 60mm x 0.6 @ max 500mm centres  |  | 34                | 135                | 30          |
|   | Facings    | 1 layer 12.5mm Fermacell Board plus 1 layer 12.5mm Powerpanel H <sub>2</sub> O one side                                   |  |                   |                    |             |
|   | Insulation | 40mm mineral stone wool density 30kg/m <sup>3</sup>   |  |                   |                    |             |
|   | Type       | Suspended steel ceiling system with fire protection from above and below. Min 0.6 gauge. Confirm hanging and layout first |  |                   |                    |             |
| <b>2H12</b>   |            |   |  |                   |                    |             |
|  | Battens    | Timber battens min 48mm x 24mm, steel resilient bar or MF suspended ceiling at max 330mm centres                          |  |                   |                    |             |
|   | Facings    | 1 layer 10mm Fermacell Board one side   |  | 16                | >40                | 30          |
|   | Insulation | 160mm x 30kg/m <sup>3</sup>   |  |                   |                    |             |
|   | Type       | Timber joisted ceiling systems with a layer of structural overlay board   |  |                   |                    |             |
|   | Battens    | Timber battens min 48mm x 24mm, steel resilient bar or MF suspended Ceiling at max 500mm centres                          |  |                   |                    |             |
|   | Facings    | 1 layer 12.5mm Fermacell Board one side   |  | 19                | 40                 | 30          |
|   | Insulation | 160mm x 30kg/m <sup>3</sup>   |  |                   |                    |             |
|   | Type       | Timber joisted ceiling systems with a layer of structural overlay board   |  |                   |                    |             |

### Fermacell CEILINGS WITH STEEL AND TIMBER SUBSTRUCTURES

### Fermacell TIMBER CEILINGS





| SYSTEM SPECIFICATIONS            |                   |  |  | Ceiling Weight    | Sound Insulation | Fire Rating |
|----------------------------------|-------------------|--|--|-------------------|------------------|-------------|
|                                  |                   |  |  | kg/m <sup>2</sup> | R <sub>w</sub>   | mins        |
| <b>2H23</b>                      |                   |  |  |                   |                  |             |
|                                  | Battens           | Timber battens min 48mm x 24mm, steel resilient bar or MF suspended ceiling at max 400mm centres |  | 29                | 45               | 60          |
|                                  | Facings           | 2 layers 10mm Fermacell Board one side   |  |                   |                  |             |
|                                  | Insulation        | 100mm mineral stone wool density 30kg/m <sup>3</sup>   |  |                   |                  |             |
|                                  | Type              | Timber joisted ceiling systems with a layer of structural overlay board                          |  |                   |                  |             |
|                                  | Battens           | Timber battens min 48mm x 24mm, steel resilient bar or MF suspended ceiling at max 400mm centres |  | 35                | 50               | 60          |
|                                  | Facings           | 2 layers 12.5mm Fermacell Board one side   |  |                   |                  |             |
|                                  | Insulation        | 100mm mineral stone wool density 30kg/m <sup>3</sup>   |  |                   |                  |             |
|                                  | Type              | Timber joisted ceiling systems with a layer of structural overlay board                          |  |                   |                  |             |
| <b>2FCH21 PARTY FLOOR DETAIL</b> |                   |  |  |                   |                  |             |
|                                  | Facings           | 2 layers 10mm Fermacell Board one side   |  | ≥305              | 60               | *≥45        |
|                                  | Insulation        | 100mm mineral wool density 30kg/m <sup>3</sup>   |  |                   |                  |             |
|                                  | Main Floor        | Min 235mm x 50mm solid timber joists at 400mm centres with 22mm chipboard overlay                |  |                   |                  |             |
|                                  | Flooring Solution | 2E31 or 2E32 Fermacell acoustic flooring element   |  |                   |                  |             |
|                                  | Ceiling Solution  | MF or resilient bar system set at max 400mm centres at 90° to joist                              |  |                   |                  |             |

| SYSTEM SPECIFICATIONS |            |  |  | Ceiling Weight    | Construction Height | Fire Rating |
|-----------------------|------------|--|--|-------------------|---------------------|-------------|
|                       |            |  |  | kg/m <sup>2</sup> | mm                  | mins        |
| <b>2HD11</b>          |            |  |  |                   |                     |             |
|                       | Battens    | Timber battens min 48mm x 24mm, steel resilient bar or MF suspended ceiling at max 330mm centres |  | 20                | 45                  | 30          |
|                       | Facings    | 1 layer 12.5mm Fermacell Board one side  |  |                   |                     |             |
|                       | Insulation | 60mm mineral stone wool density 32kg/m <sup>3</sup>  |  |                   |                     |             |
|                       | Type       | Timber joisted ceiling systems <b>without</b> a layer of structural overlay board                |  |                   |                     |             |

\* Roofing Battens

\* Sound Rating "D<sub>nw</sub> + C<sub>v</sub>"

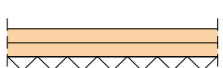
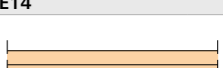
### Fermacell FLOORING

| SYSTEM SPECIFICATIONS  |                      |  | Element Weight    | Admissible Point Loading | Thickness | Fire Rating from above | Thermal Performance      |  |
|--|----------------------|--|-------------------|--------------------------|-----------|------------------------|--------------------------|--|
|  |                      |  | kN/m <sup>2</sup> | kN                       | mm        | mins                   | [1/Δ] m <sup>2</sup> K/W |  |
| <b>2E11</b><br>   | Type                 | 20mm dry flooring element  | 0.23              | 2*                       | 20        | 30                     | 0.06                     |  |
|  | Areas of Application | 1 + 2  |                   |                          |           |                        |                          |  |
| <b>2E22</b><br>   | Type                 | 25mm dry flooring element  | 0.29              | 3*                       | 25        | 60                     | 0.075                    |  |
|  | Areas of Application | 1 + 2 + 3  |                   |                          |           |                        |                          |  |
| <b>2E13</b><br>  | Type                 | 20mm dry flooring element + 20mm rigid foamed polystyrene                      | 0.23              | 2                        | 40        | 30                     | 0.56                     |  |
|  | Areas of Application | 1 + 2  |                   |                          |           |                        |                          |  |
| <b>2E14</b><br> | Type                 | 20mm dry flooring element + 30mm rigid foamed polystyrene                      | 0.23              | 2                        | 50        | 30                     | 0.81                     |  |
|  | Areas of Application | 1 + 2  |                   |                          |           |                        |                          |  |
| <b>2E31</b><br> | Type                 | 20mm element dry flooring elements + 10mm wood fibre insulating slab           | 0.25              | 3                        | 30        | 90                     | 0.26                     |  |
|  | Areas of Application | 1 + 2 + 3  |                   |                          |           |                        |                          |  |
|  | OPTION               |  |                   |                          |           |                        |                          |  |
|  | Type                 | Include 35mm element - using 25mm dry flooring 2 layers 12.5mm Fermacell Board | 0.25              | 3                        | 35        | 90                     | 0.26                     |  |
| Areas of Application   | 1 + 2 + 3            |  |                   |                          |           |                        |                          |  |

\* Where the flooring elements are laid directly onto a concrete or fully supporting stable base, then the point loading increases as follows:  
 2E11 - 3.0kN  
 2E22 - 4.0kN

Refer to Fermacell Flooring Brochure for additional information.

### Fermacell POWERPANEL FLOORING

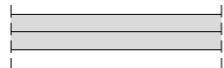
| SYSTEM SPECIFICATIONS  |                      |  | Element Weight    | Admissible Point Loading | Thickness | Fire Rating from above | Thermal Performance      |
|--|----------------------|--|-------------------|--------------------------|-----------|------------------------|--------------------------|
|  |                      |  | kN/m <sup>2</sup> | kN                       | mm        | mins                   | [1/Δ] m <sup>2</sup> K/W |
| <b>H<sub>2</sub>O TE Flooring</b><br> | Type                 | 25mm Powerpanel dry flooring element for wet areas | 0.25              | 3                        | 25        | 90                     | 0.15                     |
|  | Areas of Application | 1 + 2 + 3 (see table below)                        |                   |                          |           |                        |                          |

### RANGES OF USE AND APPLICATION\*

|   |   |
|---|---|
| 1 | Premises and corridors in buildings for habitation, hotel bedrooms with bathrooms.  |
| 2 | Offices and corridors, surgeries including wards and waiting rooms and corridors ≤ 50m <sup>2</sup> adjacent to an apartment, office or similar buildings.      |
| 3 | Corridors in hotels, retirement homes and boarding schools or similar buildings. Treatment and operating rooms not containing any heavy equipment.              |
| 3 | Areas containing tables such as classrooms, cafés, restaurants, dining rooms, lecture halls and reception lounges.  |
| 4 | Corridors in hospital buildings, retirement homes, treatment rooms and operating rooms containing heavy equipment.  |
| 4 | Areas intended for large gatherings of people, for example: classrooms, auditoria, churches, theatres, cinemas, conference rooms, waiting rooms, concert halls. |
| 4 | Large open areas, for example: museums, exhibition halls, entrances to public buildings and hotels.   |
| 4 | Sports and leisure halls, for example: dance halls, gymnasias, fitness rooms, stages, specialist shops and superstores.   |

\* Areas of application according to DIN EN 1991-1-1/ NA: 2010-12

The addition of extra layers does not restrict the range of use and does not change the resistance to concentrated loads. If the flooring elements are laid on top of a concrete slab, the allowable concentrated load rating increases to 2.5 kN for the 2E11 flooring elements and to 3.5 kN for the 2E22 flooring elements. The scope of use extends to field 3 for 2E11 and to field 4 for 2E22.



Fermacell boards are fitted and finished slightly differently to traditional plasterboard; thus speeding up the installation time by reducing drying out times and providing a more user friendly finishing system with our FST (Fine Surface Treatment).

The use of Fermacell Gypsum Fibreboards alleviates the majority of the fitting and finishing problems associated with traditional Dry Lining methods.

The screw retention capabilities of Fermacell allows most fixtures to be fitted directly to the board (see table below).

**BOARD FITTING**

Fermacell tapered edge boards are cut and fitted in a similar way to plasterboard eliminating the need for specialist tools and skills.

**BOARD JOINT REINFORCEMENT**

Fermacell's Joint filler or Jointstik provides quicker and more simple application versus traditional Dry Lining methods; with Jointstik a stronger joint can be achieved without the need for further reinforcement.

**SURFACE FINISH**

With Fermacell's FST (Fine Surface Treatment) a skim plaster type finish can be achieved in a fraction of the time without the need of specialist skills; allowing the experienced tradesman, self builder or DIY enthusiast to achieve a flawless finish.



| LOAD-CARRYING CAPACITY OF Fermacell WALLS               |   |    |    |   |   |
|---|---|----|----|---|---|
| Fermacell Gypsum Fibreboards (thickness) <sup>(1)</sup> | Loadbearing strength in kg <sup>(2)</sup><br>NB: Factor of safety 2 |    |    |   |   |
|   | Picture hooks fixed by nails  |    |    | Screw with cont. thread 5mm dia. <sup>(3)</sup> | Toggle Bolt/ Cavity Fixing <sup>(4)</sup> |
|   |   |    |    |   |   |
| 10mm  | 15  | 25 | 35 | 20  | 40  |
| 12.5mm  | 17  | 27 | 37 | 30  | 50  |
| 12.5 + 10mm   | 20  | 30 | 40 | 35  | 60  |
| 15mm  | 18  | 28 | 38 | 30  | 55  |
| 18mm  | 20  | 30 | 40 | 35  | 60  |

(1) Maximum stud centres = 50 x board thickness. N.B. Where fixings are less than 500mm apart, reduce the load per fixing by 50%. If a stud support separates the fixings, then use the full loadbearing strength shown above.  
 (2) Safety factor: 2 (Static load with relative humidity of up to 85%).  
 (3) Depth of cupboard or shelves: max. 350mm.  
 (4) Standard toggle bolt with > 4mm dia. screw. (The toggle bolt manufacturer's instruction should be followed.)

- Introduction
- Components & Accessories
- Floorings & Ceilings
- Fire Protection
- Timber Frames
- Rainscreens
- Fix & Finish
- Wet Areas
- Partitions
- Linings



### FOR ALL FERMACELL SYSTEMS

#### COMPONENTS

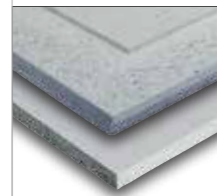

**Fermacell Board**  
Fermacell Square edge or Tapered edge.

|                  |                                |
|------------------|--------------------------------|
| <b>Thickness</b> | 10mm, 12.5mm, 15mm and 18mm    |
| <b>Sizes</b>     | 1200 x 1000mm to 1200 x 3000mm |



**Fermacell Fine Surface Treatment**  
For giving Fermacell boards a smooth finish prior to painting.

|                  |                           |
|------------------|---------------------------|
| <b>Coverage</b>  | 4-5m <sup>2</sup> per ltr |
| <b>Pack Size</b> | 3ltr or 10ltr             |



**Fermacell Joint Filler**  
For filling 5-7mm gaps between boards & stopping screw heads.

|                  |   |
|------------------|---|
| <b>Coverage</b>  | 5m <sup>2</sup> per kg for filling Tapered edge joints. 10m <sup>2</sup> for finishing glue joints and screw heads. |
| <b>Pack Size</b> | 5kg or 20kg   |



**Fermacell Jointstik**  
For edge glueing square edged Fermacell boards.

|                  |                    |
|------------------|--------------------|
| <b>Coverage</b>  | 20 lm / 310ml tube |
| <b>Pack Size</b> | 310ml tubes        |



**30/40/55mm Fermacell Screws**  
For fixing Fermacell boards to steel and timber subframes.

|                  |   |
|------------------|---|
| <b>Coverage</b>  | 13 screws per m <sup>2</sup> for walls (for each side)<br>30 screws per m <sup>2</sup> for ceilings |
| <b>Pack Size</b> | Box of 250 screws or box of 1000 screws   |

#### ACCESSORIES



**Fermacell Board Knife**  
For scoring and snapping Fermacell boards.



**Fermacell Spatula**  
For applying Fine Surface Treatment.

|             |       |
|-------------|-------|
| <b>Size</b> | 250mm |
|-------------|-------|

Metal Framing Systems or Timber by others

### FITTING FERMACELL BOARDS

#### TOOLS YOU WILL NEED



**Electric Screwdriver**  
Electric screwdriver with a minimum speed of 3500 rpm. A cordless screwdriver may be used, but check the speed first. Slower speed tools may cause lipping when installing boards on steel studwork.



**Pneumatic Gun**  
If using staples or nails, a pneumatic gun and compressor operating at 7 bar will be needed. (This equipment is available from many hire centers).



**Plumb Line**  
Plumb line or long spirit level.



**Mastic Gun**  
Mastic gun for Jointstik tubes.



**Decorator's Scraper**  
Decorator's scraper or similar for removing excess Fermacell Jointstik (after curing).



**Taping knife**  
Taping knife or plastering trowel for applying Fermacell Joint filler to the joint.



**Rigid Bladed Scoring Knife**  
Rigid bladed scoring knife, such as a Fermacell knife, for scoring and snapping the boards.



**A Circular or Jig Saw**  
A circular or jig saw may also be used. If using a hand-held electric circular saw, we recommend using a vacuum attachment to collect dust.



**Steel Trowel**  
A steel trowel for applying Fermacell FST (Fine Surface Treatment). Special Fermacell applicators are available from selected distributors.

Fermacell Gypsum Fibreboards can be installed on to a variety of backgrounds; typically Metal studs, Timber studs, directly bonded, or mounted on a SFS frame to exterior walls.

#### GENERAL SITE GUIDELINES.

Fermacell components should not be installed when the mean relative humidity is  $\geq 80\%$ .

Fermacell boards should be fixed at a mean relative humidity of  $\leq 80\%$  and a room temperature of  $+5^\circ\text{C}$ . The temperature of the adhesive should be  $+10^\circ\text{C}$ .

The boards must be acclimatised to the installation area, and in the 12 hours after jointing the relative room climate should not change significantly. Lower temperatures prolong curing times.

Filling joints with Joint filler and the application of FST should only be carried out at a mean relative humidity of  $\geq 70\%$  (corresponding to a board moisture content of  $\leq 1.3\%$ ), and the room temperature should be  $+5^\circ\text{C}$ .

Wet trades or wet screeding, or asphaltting should be completed prior to joint filling. The adhesive method of jointing can be used prior to these applications, however, check with the our Technical Department first on **+44 (0) 121 311 3480**.

Gas burner heating can damage the boards due to the risk condensation and thermal shock. This applies particularly to cold interiors with poor ventilation. Rapid heating, which can result in thermal shock, must be avoided.

FINISHING

FINISHING



**SKIM, PLASTERS AND TEXTURED PLASTERS**

A plaster finish is not normally recommended as the same finish can be achieved using FST, which is much faster and a fraction of the cost. Where a skim is to be used, for whatever reason, our recommendation is that the boards should be sealed with a Board Sealer or High Suction Plaster Primer, as recommended by the skim manufacturer. Fibre tape must be applied to all joints, and a test area of at least 1m<sup>2</sup> should be completed first, to confirm compatibility / suitability.

**PAINTING**

Fermacell boards can be painted directly. Refer to our instruction manual for recommendations for joint treatment in this case. Fermacell FST gives a smooth surface ready to accept a paint finish. Typically a mist coat and two undiluted top coats are required. Where vinyl or oil based paints are to be used without the prior application of FST, we recommend the boards are sealed first.

We do not recommend the use of eggshell paint finishes. However, where eggshell paints are used, a minimum of two coats of FST must be applied first, followed by a sealant. In all cases, refer to the relevant British standards. In all cases, the paint manufacturers recommendations should be followed.

**TILING**

Before tiling, all areas should be clean and free from dust. If a priming coat is required, this should be allowed to dry for 24 hours before tiling work starts.

Wet areas like showers and bathrooms, which are subject to frequent splashing, should be treated with a waterproofing solution such as the Fermacell Waterproofing Application. This is a paintable system suitable for use with cement based adhesives. Tile adhesives with a low water content should be used and tiles fixed with a thin bead adhesive method, without pre-wetting.

Generally tiles should not be grouted for a 24 hour period after fixing. Follow the adhesive and tile manufacturer's recommendations. Wall surfaces that require sealing must be protected against

the penetration of water to a height of 2000mm above the bath floor, with adequate spacing above the actual shower and bath areas. For showers, waterproofing must extend to at least 300mm above the shower head.

Corners and penetration should be sealed with recommended sealing tapes or collars. It is recommended that all walls in any shower or bathroom are sealed against rising moisture to a height of 150mm. In all cases refer to manufacturers instructions. Fermacell recommends a maximum tile size of 300mm x 300mm. For larger tiles please contact our Technical Department on **+44 (0) 121 311 3480**.

Wet Areas  
Fix & Finish  
Installation Overview  
Rainscreens  
Timber Frames  
Fire Protection  
Detailed Overview  
Floorings & Ceilings  
Components & Accessories  
Linings  
Partitions  
Introduction

Wet Areas  
Fix & Finish  
Installation Overview  
Rainscreens  
Timber Frames  
Fire Protection  
Detailed Overview  
Floorings & Ceilings  
Components & Accessories  
Linings  
Partitions  
Introduction

**FITTING FERMACELL BOARDS**

**FITTING FERMACELL BOARDS**

**1. STUDWORK**



If you are using a steel subframe, a minimum 50mm fixing face and a 0.6mm gauge stud must be used, with associated head and floor track to suit - e.g. fermacell steel product range. If you are using timber for the subframe, you will need (75mm x 50mm) P.S.E. well seasoned timber for both the vertical studwork and the head and floor track. An 89mm x 38mm studs may be used, but only with the adhesive or Tapered edge jointing system.

Allow for full height stud every 500mm of wall length when using 1500mm x 1000mm one-man boards, or every 600mm of wall length when using other sizes in 12.5mm thickness or every 400mm of wall length when using 10mm thickness, plus one extra stud for the final wall fix. Allow two times the wall length for the head and floor tracks. In all cases ensure that studwork spacing is suitable for the size of board to be used.

**2. FIXING**



For the steel frame use ≥ 40mm screws with wall plugs (if appropriate) for fixing head and floor tracks, and end studs to the existing structure. Allow for fixing frame anchors at max 600mm centres. Intermediate studs are not fixed to the head and floor track.

For timber frame use ≥ 80mm screws with wall plugs (if appropriate) for fixing head and floor tracks and end studs to the existing structure. Allow for fixing frame anchors at max 600mm centres. Use 100mm round headed nails for screw fixing the studs to the head and sole plate (3 per fixing, 6 per stud).

**3. MINERAL FIBRE INSULATION**



For most general applications we recommend 40mm thick, 48kg/m<sup>3</sup> mineral fibre insulation in batt or roll form. The width of the insulation should match the stud spacing (see note 1).

This grade of insulation gives excellent all round thermal and acoustic properties and when used in conjunction with 12.5mm board provides F60 partitions (see Fermacell systems 1S21 and 1H22).

**4. FERMACELL BOARDS**

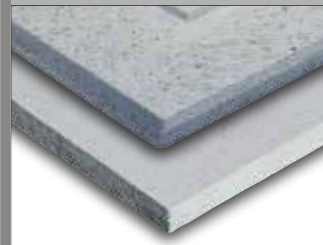

Fermacell boards available in both Square and Tapered edge (2 sides and 4). For board sizes please refer to board size table on page 8. Square edge boards can be easily fitted and finished using Fermacell Jointstik and Fine Surface Treatment.

\*For double layers systems the base layer should be square edged Fermacell. If Tapered edge Fermacell is used as a base layer then all joints must be filled with Fermacell filler, prior to fitting the outer layer of board.

Our Tapered edge boards are designed to accommodate a joint reinforcement tape as with traditional Dry Lining. Once the tape has been bedded into place and the Tapered area filled and the Fermacell Filler is set the entire surface is then coated with Fine Surface Treatment.

**5. FERMACELL SCREWS**



The boards should be screwed to the studs or frame using Fermacell screws (3.9 x 30mm) at 250mm centres along the studs. Staples should be 38mm long, have a head width of 10mm and be a minimum of 1.4mm gauge.

Nails should be galvanised, 45mm long and a minimum of 2.2mm gauge. Staples and nails should be fixed at 200mm centres. Refer to the fixings tables for specific fixings information dependant on Fermacell thickness and application. Fixings should be 10mm from the edge of the board, and 50mm from corners. Please fixing sequence in table 5b.

**NB:** For screw spacing and usage for wall and ceilings please refer to our Dry Lining Wall & Ceilings Guide. Fermacell boards are fixed at the following maximum screw centres:-  
(1) Wall 250mm  
(2) Ceiling 200mm

**6 FERMACELL JOINTSTIK**



Jointstik is used for gluing square edge boards together. Each cartridge will cover 20 linear meters of joint using a 3mm bead. This equates to approximately 8 boards.

Fermacell Jointstik adhesive is applied to the edge of the board in a continuous 3mm bead prior to fixing the next board.

Because the adhesive expands on contact with air, the bead should be applied to the edge of square edge boards and not the 'V' between the tapers of Tapered edge boards.

If the bead is applied incorrectly, excess Jointstik may be trapped between board and subframe causing subsequent lipping.

**7 FERMACELL JOINTSTIK**



Once Jointstik is applied the next board is then fitted to the subframe, spreading the adhesive across the face of the board edge and ensuring a tight fit of less than 1mm. Allow the adhesive to harden fully before attempting to remove any excess (typically 24 hours). Once hardened, the excess can be struck off with a decorator's scraper. There is no requirement for noggings behind these joints. The final gap between boards with Jointstik should be less than 1mm.

Any greater than this may result in weaker joints. If Jointstik has been for a long period it may be hard to remove, a Surfform or any similar tool may be used to remove it. The joint and screw heads should then be filled with Fermacell Joint Filler. All joints above 2500mm partition height must be jointed using Jointstik or reinforced with noggings. Horizontal joints are jointed in the same manner as vertical joints.

**8 FERMACELL JOINT FILLER**



A hard filler used for jointing Tapered edge boards, jointing the gaps between cut edges and for filling screw heads. As well as an alternative to Jointstik when using square edge boards.

\*For double layers systems the base layer should be square edged Fermacell. If Tapered edge Fermacell is used as a base layer then all joints must be filled with Fermacell filler, prior to fitting the outer layer of board.

If using Tapered edge boards, jointing tape will be required. We recommend a paper tape rather than a self adhesive fibre tape as this gives a stronger joint. When using Fermacell Joint Filler for Tapered edge boards, allow 1kg per 4 meters of joint length, and 1kg per 7-8 meters of joint length for jointing off cuts.

**9 FERMACELL JOINT FILLER**



**Offcuts and Square edge boards**

Fermacell Joint Filler may be used to joint square Edge boards and off cuts. Where square edge boards or offcuts are installed prior to jointing, a 5 – 7mm gap is left between boards, which is then filled with Fermacell Joint Filler ensuring that the joint filler is pushed fully through the gap. (Fermacell Jointstik adhesive is not a gap filler). The filler can then be rubbed down prior to final decoration. Ensure filled joints are backed/supported.

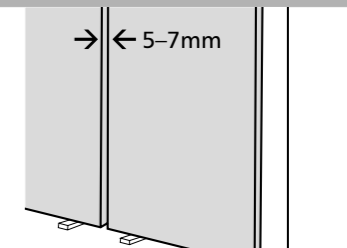

**10 FLEXIBLE SEALANT**



For use in sealing the gap between boards and other material surfaces such as walls, floors and ceilings. Typically, this should be where any building movement is expected on internal corners or abutments. Typically a 3 – 5mm gap should be left.

The edges of the boards must be primed prior to application, and the sealant should be fire or acoustic rated as required.

FITTING FERMACELL BOARDS

FIXING CENTRES AND USAGE ON WALLS AND CEILINGS

5b. FIXING SEQUENCE

When fixing boards in a double height partition, cross joints must be avoided by installing boards as shown in *Diagram A*. When fixing boards, work from one side of the board to the other (e.g. from left to right) or from the centre outwards. Don't fix the four corners first as this can set up stresses in the board. Ensure that there is a gap at junctions with other adjoining surfaces. This applies to both layers of a double layer partition system. See *Diagram B*.

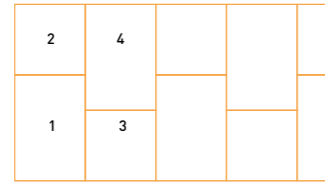

Diagram A

When using Fermacell square edge one-man boards (1500mm x 1000mm), you should alternate the orientation of the boards as shown in *Diagram C*. This sequence prevents cross joints. A similar system for using 1200mm x 1200mm taper edge boards (Tapered on 4 sides) is shown in *Diagram D*. All joints should be staggered by a minimum of 200mm both horizontally and vertically.

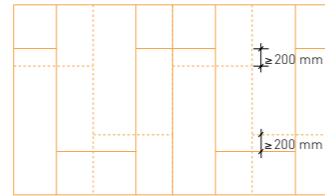

Diagram B

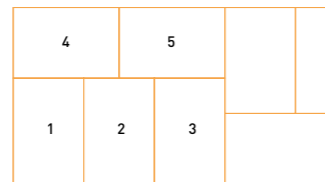

Diagram C

Isolation Strips

Typically strips 50mm to 75mm wide and 10mm thick, these should be sized to suit the wall thickness. These can be either purchased as a roll or may be offcuts from the insulation material from the wall.

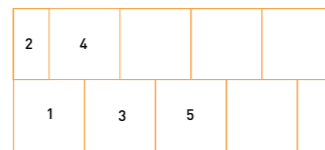
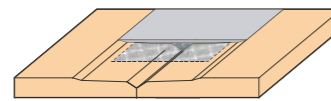

Diagram D

Fixing and jointing Tapered edge boards

Tapered edge boards are fitted to the subframe with the board edges touching. The boards are jointed using Fermacell Joint Filler and is applied to the joint, ensuring that the central 'V' of the joint is fully filled, paper tape is bedded into the joint and the filler is struck off flush with the taper.



Joint variation 1: Two factory Tapered edge boards with Fermacell Jointing Tape and Fermacell Joint Filler

Self adhesive fibre tape may be used instead of paper tape and the filler pushed through the mesh to the back of the joint. Please note that the joint strength when using fibre tape is less than paper tapes and cracking may occur in certain circumstances. Once the filler is dry, a second fill may be necessary to take up any shrinkage, fill the screw heads and apply Fine Surface Treatment to the entire surface.

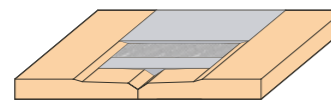

Joint variation 2: Two factory Tapered edge boards with paper tape and Fermacell Joint Filler

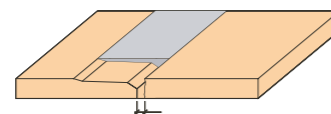

Joint variation 3: One factory Tapered edge board and one edge cut on-site, bevelled and chamfered, with Fermacell Jointing Tape and Fermacell Joint Filler

Typical guidance for fixing usage - per side and m<sup>2</sup>

| BOARD THICKNESS                                     | Staples (galvanised and resinated)<br>Gauge ≥ 1.5mm, Head Width ≥ 10mm |              |                           | Fermacell screws<br>Gauge = 3.9mm |              |                           |
|---|--|--------------|---------------------------|-----------------------------------|--------------|---------------------------|
|   | Length (mm)  | Spacing (mm) | Use (no./m <sup>2</sup> ) | Length (mm)                       | Spacing (mm) | Use (no./m <sup>2</sup> ) |
| <b>Fixing Fermacell to Walls</b>                    |  |              |                           |                                   |              |                           |
| <b>Metal – single-layer</b>                         |  |              |                           |                                   |              |                           |
| 10mm  | –  | –            | –                         | 30                                | 250          | 13                        |
| 12.5mm  | –  | –            | –                         | 30                                | 250          | 10                        |
| 15mm  | –  | –            | –                         | 30                                | 250          | 10                        |
| 18mm  | –  | –            | –                         | 40                                | 250          | 10                        |
| <b>Metal – 2 layered / 2nd. layer into the stud</b> |  |              |                           |                                   |              |                           |
| 1st Layer: 12.5mm                                   | –  | –            | –                         | 30                                | 400          | 6                         |
| 2nd Layer: 10mm or 12.5mm                           | –  | –            | –                         | 40                                | 250          | 10                        |
| 1st Layer: 15mm                                     | –  | –            | –                         | 30                                | 400          | 6                         |
| 2nd Layer: 12.5mm or 15mm                           | –  | –            | –                         | 40                                | 250          | 10                        |
| <b>Wood – single layer</b>                          |  |              |                           |                                   |              |                           |
| 10mm  | ≥30  | 200          | 16                        | 30                                | 250          | 13                        |
| 12.5mm  | ≥35  | 200          | 12                        | 30                                | 250          | 10                        |
| 15mm  | ≥44  | 200          | 12                        | 40                                | 250          | 10                        |
| <b>Wood – 2 layered / 2nd. layer into the stud</b>  |  |              |                           |                                   |              |                           |
| 1st Layer: 12.5mm                                   | ≥35  | 400          | 6                         | 30                                | 400          | 6                         |
| 2nd Layer: 10mm or 12.5mm                           | ≥50  | 200          | 12                        | 40                                | 250          | 13                        |

| BOARD TO BOARD FIXING                           | Diverging Staples. Maximum Row spacing 400mm<br>Gauge ≥ 1.5mm, Head Width ≥ 10mm |              |                           | Fermacell screws. Gauge = 3.9mm<br>Maximum Row spacing 400mm |              |                           |
|---|--|--------------|---------------------------|--|--------------|---------------------------|
|   | Length (mm)  | Spacing (mm) | Use (no./m <sup>2</sup> ) | Length (mm)  | Spacing (mm) | Use (no./m <sup>2</sup> ) |
| <b>Wall zone per m<sup>2</sup> wall surface</b> |  |              |                           |  |              |                           |
| 10mm Fermacell on 10mm Fermacell                | 18 – 19  | 150          | 32                        | 30   | 150          | 26                        |
| 12.5mm Fermacell on 12.5 or 15mm Fermacell      | 21 – 22  | 150          | 32                        | 30   | 150          | 26                        |
| 15mm Fermacell on 15mm Fermacell                | 25 – 28  | 150          | 32                        | 30   | 150          | 26                        |
| 18mm Fermacell to 18mm Fermacell                | 31 – 34  | 150          | 32                        | 40   | 150          | 26                        |

| BOARD THICKNESS   | Staples (galvanised and resinated)<br>Gauge ≥ 1.5mm, Head Width ≥ 10mm |              |                           | Fermacell screws<br>Gauge = 3.9mm |              |                           |
|---|--|--------------|---------------------------|-----------------------------------|--------------|---------------------------|
|   | Length (mm)  | Spacing (mm) | Use (no./m <sup>2</sup> ) | Length (mm)                       | Spacing (mm) | Use (no./m <sup>2</sup> ) |
| <b>Fixing Fermacell to Ceilings</b>                             |  |              |                           |                                   |              |                           |
| <b>Metal – single-layer</b>                                     |  |              |                           |                                   |              |                           |
| 10mm  | –  | –            | –                         | 30                                | 200          | 22                        |
| 12.5mm  | –  | –            | –                         | 30                                | 200          | 19                        |
| 15mm  | –  | –            | –                         | 30                                | 200          | 16                        |
| <b>Metal – double-layer / 2nd layer into the sub-structure</b>  |  |              |                           |                                   |              |                           |
| 1st Layer: 10mm   | –  | –            | –                         | 30                                | 300          | 16                        |
| 2nd Layer: 10mm   | –  | –            | –                         | 40                                | 200          | 22                        |
| 1st Layer: 12.5mm   | –  | –            | –                         | 30                                | 300          | 14                        |
| 2nd Layer: 12.5mm   | –  | –            | –                         | 40                                | 200          | 19                        |
| 1st Layer: 15mm   | –  | –            | –                         | 30                                | 300          | 12                        |
| 2nd Layer: 12.5mm or 15mm                                       | –  | –            | –                         | 40                                | 200          | 16                        |
| <b>Timber – single layer</b>                                    |  |              |                           |                                   |              |                           |
| 10mm  | ≥30  | 150          | 30                        | 30                                | 200          | 22                        |
| 12.5mm  | ≥35  | 150          | 25                        | 30                                | 200          | 19                        |
| 15mm  | ≥44  | 150          | 20                        | 40                                | 200          | 16                        |
| <b>Timber – double-layer / 2nd layer into the sub-structure</b> |  |              |                           |                                   |              |                           |
| 1st Layer: 10mm   | ≥30  | 300          | 16                        | 30                                | 300          | 16                        |
| 2nd Layer: 10mm   | ≥44  | 150          | 30                        | 40                                | 200          | 22                        |
| 1st Layer: 12.5mm   | ≥35  | 300          | 14                        | 30                                | 300          | 14                        |
| 2nd Layer: 12.5mm   | ≥50  | 150          | 25                        | 40                                | 200          | 19                        |
| 1st Layer: 15mm   | ≥44  | 300          | 12                        | 40                                | 300          | 12                        |
| 2nd Layer: 12.5mm or 15mm                                       | ≥60  | 150          | 22                        | 40                                | 200          | 16                        |

| BOARD TO BOARD FIXING                                 | Diverging Staples. Maximum Row spacing 300mm<br>Gauge ≥ 1.5mm, Head Width ≥ 10mm |              |                           | Fermacell screws. Gauge = 3.9mm<br>Maximum Row spacing 300mm |              |                           |
|---|--|--------------|---------------------------|--|--------------|---------------------------|
|   | Length (mm)  | Spacing (mm) | Use (no./m <sup>2</sup> ) | Length (mm)  | Spacing (mm) | Use (no./m <sup>2</sup> ) |
| <b>Ceiling zone per m<sup>2</sup> ceiling surface</b> |  |              |                           |  |              |                           |
| 10mm Fermacell on 10mm Fermacell                      | 18 – 19  | 120          | 35                        | 30   | 150          | 30                        |
| 12.5mm Fermacell on 12.5 or 15mm Fermacell            | 21 – 22  | 120          | 35                        | 30   | 150          | 30                        |
| 15mm Fermacell on 15mm Fermacell                      | 25 – 28  | 120          | 35                        | 30   | 150          | 30                        |

FINISHING

An alternative to skim plaster finish, our simple FST system gives a fast and easy equivalent that this dry in 45 minutes, ready to accept a paint finish.

**SURFACE PREPARATION**

The surface should be dry and free of stains and dirt. Any damage or indentations must be filled with Fermacell Joint filler and allowed to dry. Before any decoration, the moisture content of the boards must be less than 1.3%. This moisture content will be achieved automatically within 48 hours if the relative humidity of the air is kept below 70%, the air temperature is over 15°C and the boards are stored off the ground in well ventilated conditions.

**FERMACELL FST (FINE SURFACE TREATMENT)**

FST is a ready-mixed face filler used for smoothing the surface of the boards. A 10 litre tub will cover approximately 40-50m<sup>2</sup> of wallboard. FST is used where an equivalent of skim-coat smoothness is required. FST can also be used for a feather fill over Tapered edge board joints, prior to the final finish coat as described above.



**USE OF FST**

Apply straight from the tub using a trowel or a Fermacell FST applicator. Work on 1-2m<sup>2</sup> at a time and ensure that the surface is fully covered. Then remove the excess FST in a smoothing out motion using a trowel or a FST applicator. Do not scrape off too hard or too much will be removed. The FST will dry within 45 minutes and subsequent layers can be applied as required. If necessary, smooth the surface with 'fine 240 grit' sandpaper, prior to final decoration.

**WALLPAPERING**

With the exception of vinyl wallpapers, all types of paper can be applied to Fermacell using standard trade pastes, without priming the surface. When using vinyl papers, it is recommended that the board is primed and a suitable paste is used.

CREATING CORNERS

**INTERNAL CORNERS**

There are a number of ways to construct an internal corner depending on the installers preference.

**FERMACELL TO EXISTING SUBSTRATES**

Leave a 3-5mm gap between the Fermacell and other building backgrounds, the gap can then be filled with a flexible decorators' filler. The boards then can be over coated with Fermacell Fine Surface Treatment (FST) at the same time as finishing coat is applied to the boards.

**FERMACELL TO FERMACELL USING FERMACELL JOINT FILLER**

Leave a 5-7mm gap at the junction between the boards, the gap is filled using Fermacell Joint Filler

A paper jointing tape, if desired, can be bedded over the filled gap using an additional coat of Fermacell Joint Filler.

Once the filling material and tape (if used) had dried the corner is then over coated with Fermacell Fine Surface Treatment (FST) at the same time as the rest of the boards.

**FERMACELL TO FERMACELL USING A FLEXIBLE FILLER**

Leave a 3-5mm gap the gap at the junction between the boards the gap is filled using a flexible filler.

A paper jointing tape, if desired, can be bedded over the filled gap using a coat of Fermacell Joint Filler.

Once the filling material and tape (if used) had dried the corner is then over coated with Fermacell Fine Surface Treatment (FST) at the same time as the rest of the boards.

**EXTERNAL CORNERS**

Fermacell boards are strong enough to withstand day to day impacts on external corners with out the requirement of additional corner protection.

To create an external corner the boards should be aligned flush and fixed to the stud using Fermacell screws or staples with timber studs and secured with Fermacell Jointstik.

Once the Jointstik is dry it can then be struck off and any deviation dressed with Fermacell Joint Filler. A final coat of Fermacell Fine Surface Treatment is then applied the corner at the same time as the rest of the board.

Alternatively the boards are fixed to the studs leaving a 5-7mm gap, which is then filled with Fermacell Joint Filler. And then finished as above.

The installer may elect to use protection in areas of extreme activity or when they are looking for uniformity of the angle. This can be provided by bedding a steel reinforced paper bead or suitable skim bead to the corner using Fermacell Joint filler and over coating with Fermacell Fine Surface Treatment.

Wet Areas  
Fix & Finish  
Rainscreens  
Timber Frames  
Fire Protection  
Floorings & Ceilings  
Linings  
Partitions  
Introduction  
Components & Accessories  
Detailed Overview  
Installation Overview

Wet Areas  
Fix & Finish  
Rainscreens  
Timber Frames  
Fire Protection  
Floorings & Ceilings  
Linings  
Partitions  
Introduction  
Components & Accessories  
Detailed Overview  
Installation Overview

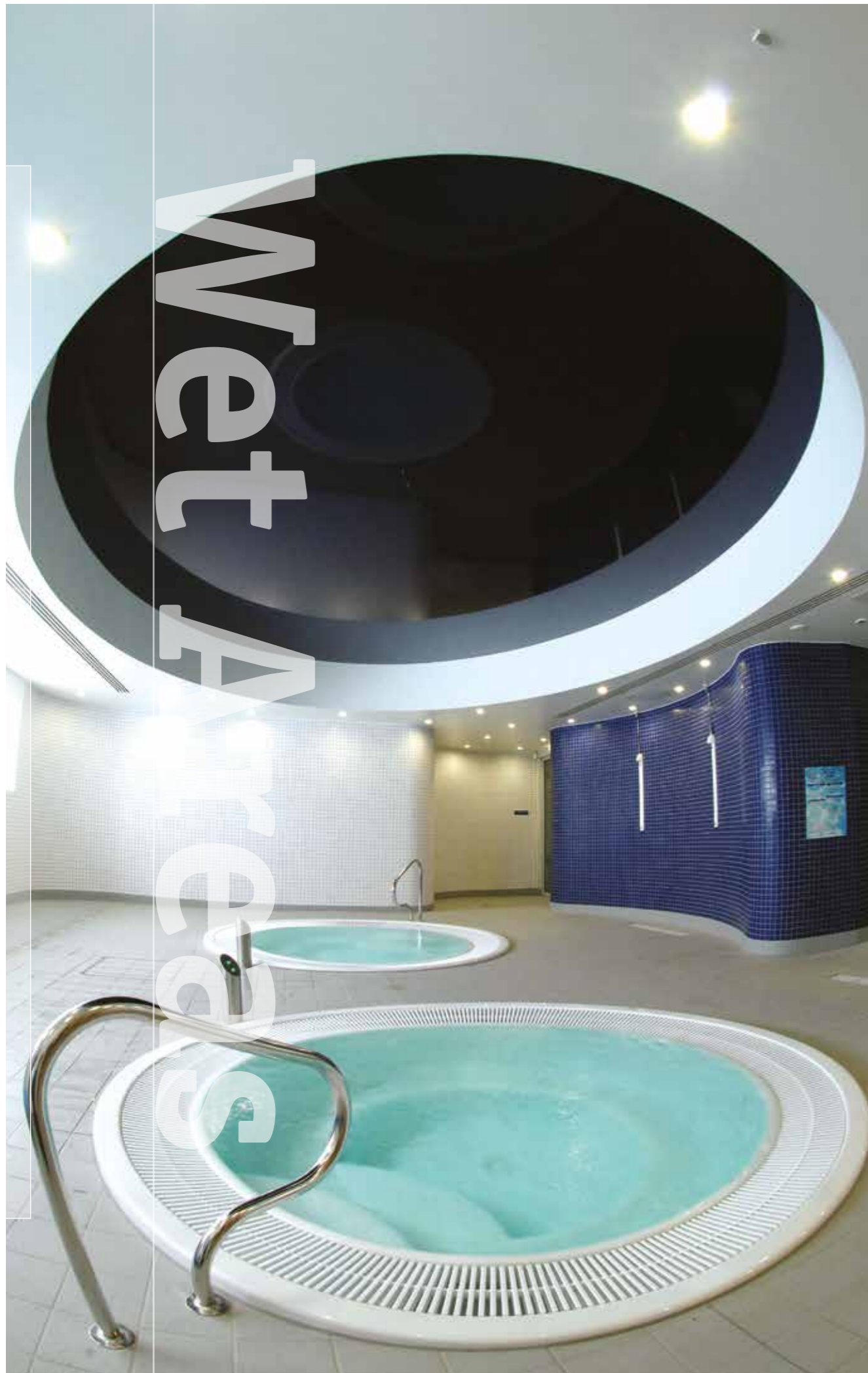

MARKET SECTORS

- ▶ Self build
- ▶ New build
- ▶ Factory built
- ▶ Recreation

PERFORMANCE RATINGS

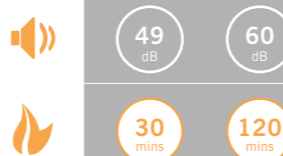

Fermacell PERFORMANCE

- ▶ Impact – Severe duty, able to withstand impact from people as well as objects (door handles etc).
- ▶ Acoustics – Greater acoustic performance often with less layers than plasterboard constructions providing slimmer partitions.
- ▶ Loadbearing – Fermacell gives a category 1 racking strength. Fermacell also provides structural solutions to Euro Code 5.
- ▶ Speed of construction – Due to the unique finishing system (FST) the overall installation of Fermacell is faster and easier.

From shower areas to swimming pools and wet areas water-proofing has always provided a challenge for the developer.

Fermacell has three options for exposure to water and moisture.

**FERMACELL GYPSUM FIBREBOARDS**

In general domestic applications and where the relative humidity does not exceed 80% or where protection from water is provided by tiles, regular Fermacell Gypsum Fibreboards can be used in partitions and linings.

**FERMACELL POWERPANEL H<sub>2</sub>O BOARDS AND FLOORING ELEMENTS**

For shower and wet areas in commercial and domestic applications, Fermacell Powerpanel H<sub>2</sub>O board provides an impervious to water solution. H<sub>2</sub>O boards can also be used for semi exposed external applications such as soffits.

**FERMACELL GYPSUM FIBREBOARDS WITH FERMACELL WATERPROOFING SYSTEM**

The Fermacell Waterproofing system is for surface sealing Fermacell boards against moisture providing an impervious coating. This allows the installer/ developer to utilise the benefits of Fermacell and sealing the boards against water in wet areas (splashback areas) at the same time.

- Introduction
- Partitions
- Components & Accessories
- Linings
- Floorings & Ceilings
- Detailed Overview
- Fire Protection
- Component Details
- Timber Frames
- Installation Overview
- Rainscreens
- Fix & Finish
- Wet Areas

## FERMACELL PARTITION WALLS ON STEEL SUBFRAMES

## FERMACELL PARTITION WALLS ON STEEL SUBFRAMES

### Fermacell's Powerpanel H<sub>2</sub>O board at the heart of new Evesham Leisure Centre.

More than 20,000 square metres of Powerpanel H<sub>2</sub>O board has been used in three different types of application within a superb new £11m Leisure Centre complex built for Wychavon District Council in Worcestershire.



Evesham Leisure Centre's facilities include a 25 metre swimming pool and a 12 metre studio pool. Both pools partition walls are lined with Fermacell Powerpanel H<sub>2</sub>O boards, which provide an ideal base for tiling and other wall finishes. In addition, 12.5mm Fermacell Gypsum Fibreboard has also been utilised as an external backing board for the building's cladding, as well as on many of the interior walls.

The aesthetically pleasing building - designed by project architects Roberts Limbrick - features a dramatic green, copper clad curved entrance and climbing wall enclosure providing a unique, recognisable focus to the 4,500m<sup>2</sup> Centre, which has been developed to replace an outdated facility developed more than 30 years ago.



### FACILITIES

The main entrance to the Centre leads directly to the main foyer space which contains a dramatic climbing wall, reception and a café with views directly into the pool area and up to the fitness suite above. The reception area leads to a multi purpose room providing facilities for dance, exercise classes, soft play and functions. There is also a pool, sports hall and changing facilities on this floor.

A large changing area leads to a 25m x 5-lane level deck Community Pool, a separate 13m x 7m level deck Studio Pool, with movable floor for flexibility of use and the Spa Suite which includes two Pools, a Steam Room and a Sauna. Spectator access to the main pool is provided direct from the café area.

Brian Dukes, Site Manager for main contractors Galliford Try, commented: "We specified the use of Fermacell's H<sub>2</sub>O board for this project due to its high water resistance and acoustic performance.

Internally Fermacell Gypsum Fibreboards (with glued joints) were used by the sub contractor for Galliford Try, providing lightweight partitions, achieving all the requirements for fire, acoustics and severe duty rating using a single board rather than using many different combination of boards. This enabled partition walls to be constructed both rapidly and to the required standard providing a very high quality, robust finish throughout the first floor. A high standard of finish to the pool side Powerpanel partitions was achieved with the Powerpanel H<sub>2</sub>O ready mixed surface finish.



Wet Areas  
Fix & Finish  
Installation Overview  
Rainscreens  
Component Details  
Timber Frames  
Fire Protection  
Detailed Overview  
Floorings & Ceilings  
Components & Accessories  
Linings  
Partitions  
Introduction

Wet Areas  
Fix & Finish  
Installation Overview  
Rainscreens  
Component Details  
Timber Frames  
Fire Protection  
Detailed Overview  
Floorings & Ceilings  
Components & Accessories  
Linings  
Partitions  
Introduction

### GENERAL DOMESTIC USE

#### STANDARD FERMACELL BOARDS

Standard Fermacell Gypsum Fibreboards have a high moisture resistance capability and can perform up to relative humidity up to 80%.

Standard fermacell Gypsum Fibreboards are ready to accept tiles with no need for special primers.

This makes standard Fermacell Gypsum Fibreboards a cost effective and simple solution for domestic bathroom and kitchen walls and ceilings.

For wet rooms and in areas where painted finish will be applied, standard fermacell Gypsum Fibreboards can be waterproofed with fermacell waterproofing solution. Contact our technical department for more details.

#### PRIMER SEALER



For sealing the Fermacell boards and Powerpanel H<sub>2</sub>O

#### FLEXIBLE SEALING TAPES



For watertight corner and joint protection

The Fermacell Waterproofing system is:

- Impermeable to water
- Free of solvents and softening agents
- Quick drying time of 2 to 3 hours
- Superior adhesive strength and excellent crack resistance
- Compatible with tile adhesives, solvent free coatings and sealants

#### 30/50MM FERMACELL POWERPANEL SCREWS



For fixing Powerpanel H<sub>2</sub>O boards to steel or timber studs.  
Coverage  
20m<sup>2</sup> walls  
22m<sup>2</sup> ceilings  
Pack size  
500 (35mm)  
500 (50mm)

#### WATERPROOFING APPLICATION



For waterproofing Fermcell boards in splashback areas, and for sealing internal corners with Powerpanel H<sub>2</sub>O

#### TILING

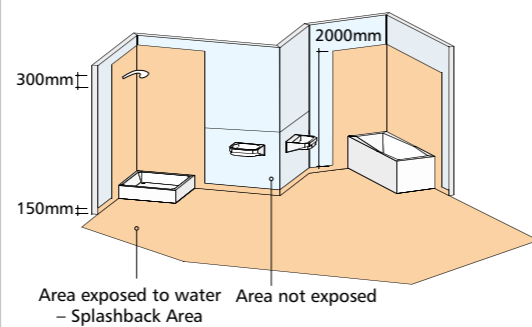

### COMMERCIAL, WET AREAS AND EXTERNAL APPLICATIONS

#### FERMACELL POWERPANEL H<sub>2</sub>O BOARDS



Fermacell Powerpanel H<sub>2</sub>O is a cement-bonded light concrete construction board with a laminated structure, reinforced on both sides with an alkali-resistant glass fibre mesh (5mm x 5mm), Fermacell Powerpanel H<sub>2</sub>O is a non-combustible Class A1 material for internal and external applications.

Powerpanel H<sub>2</sub>O is a water resistant board for bathrooms, kitchens and wet rooms in domestic and commercial projects.

The properties of Powerpanel H<sub>2</sub>O make it suitable for use in swimming pools, in this instance special treatment to the steel profiles is required.

The Fermacell Waterproofing system can be used to further enhance the performance of the Powerpanel H<sub>2</sub>O system.

#### POWERPANEL H<sub>2</sub>O FLOORING

Fermacell Powerpanel H<sub>2</sub>O flooring is an addition to our flooring range enabling the complete waterproof construction of wet areas including preformed drainage and shower tray outlets.

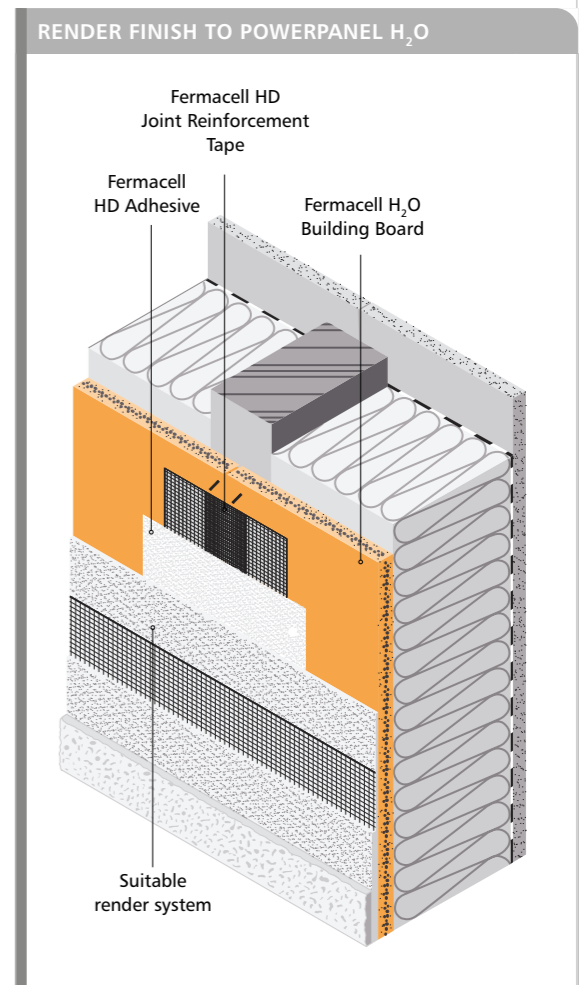



### POWERPANEL H<sub>2</sub>O INSTALLATION

#### CUTTING



Powerpanel H<sub>2</sub>O boards can be cut in a similar way to regular Fermacell boards either using a standard rail guided hand held circular saw with a tungsten tipped blade or cut by hand saw.

#### BOARDING



Install insulation (if required) making sure that there is a cavity between the insulation and one face of the Powerpanel H<sub>2</sub>O boards. Cut the boards 10mm less than the room height and install tight to the ceiling line.

#### FIXING



Screw fix the boards using Fermacell H<sub>2</sub>O screws at ≤ 250mm centres or staple at ≤200mm centres.

#### JOINTING



Apply Fermacell Jointstik to the edge of the board and position the next board once the Jointstik has dried (approx 8 hours) remove the excess with a scraping knife.

#### FINISHING



Where the Powerpanel H<sub>2</sub>O boards are not being tiled the whole surface can be finished with Fermacell Powerpanel H<sub>2</sub>O Surface Finish which is available ready mixed. The joints can be further reinforced with a self adhesive fibre tape.

Prior to tiling in permanently wet areas Powerpanel H<sub>2</sub>O boards must be sealed with Fermacell Primer and taped at internal corners with Flexible Sealing Tape.

For Powerpanel H<sub>2</sub>O Movement Joints must be placed at maximum 8m intervals

Do not Tile over Powerpanel Surface Finish. Tiles must be fixed directly to Powerpanel H<sub>2</sub>O Boards.

#### Absorption

The use of a porous material to convert sound energy into heat.

**Absorption Material**  
Sound energy absorbing material.

**Airborne Sound**  
Noise sources such as speech and television transmitted through the air.

**Airborne Sound Insulation**  
Sound insulation that reduces the transmission of airborne sound.

**Angle Bead**  
Metal or plastic angle used to reinforce external corners.

**Board Knife**  
Fermacell knife for scoring and snapping Fermacell boards.

**Bonding Agent**  
Liquid preparation applied to walls or ceilings prior to finishing.

**Bonding Compound**  
A gypsum based compound which provides an adhesive for Fermacell boards.

**Bonded Levelling Compound**  
Cement levelling compound for levelling uneven floors.

**Caulk**  
Flexible sealing material.

**Composite Resilient Batten**  
A timber batten with a pre-bonded resilient material isolating the flooring surface layers and floor base.

**Control joint**  
A joint that caters for lateral expansion or contraction allowing relatively small movements without damage to the internal surface.

**Ctr**  
Spectrum adaptation term (no. 2) from BS EN ISO 717-1: 1997 taking account of a specific sound spectre, predominately low frequency based, representing 'A' weighted urban noise.

**Cut End**  
End of a Fermacell board.

**Decibel (dB)**  
A unit of magnitude for sound pressure, sound intensity, sound power and sound insulation through the measurement of sound reduction brought about by the insulation.

**Deflection Head**  
A feature that ensures integrity at the head of a partition allowing floor slab or beam deflection.

**Density (kg/m<sup>3</sup>)**  
Mass per unit volume expressed in kilograms per cubic metre.

**DIN standard metal**  
Metal stud ceiling channel or Lining framework at least .6mm gauge thick metal with a 50mm fixing face.

**Direct Transmission**  
Sound transmitted only through the main separating element involving no other flanking element.

**Dry Lining**  
The use of plasterboard or Gypsum Fibreboard rather than solid plaster to create a wall or ceiling lining.

**Dry Levelling Compound**  
For levelling uneven floors.

**Dwang**  
See nogging.

**Edge Profile**  
Square or tapered edge of Fermacell board.

**Expansion Joints**  
A permanent joint between different parts of a structure allowing small movement without damage to the surface.

**Field of Board**  
The surface of the Fermacell board.

**Fine Surface Treatment (FST)**  
A Dolomite marble latex emulsion for finishing Fermacell boards, applied to the whole surface.

**Flanking Sound**  
The structure-borne transmission of sound between adjacent rooms or spaces that by pass the obvious barriers.

**Flexible Sealing Tape**  
Corner and joint protection for the Fermacell waterproofing system.

**Flooring Element**  
Fermacell dry flooring element for screeding, levelling and insulating floors.

#### Floor Glue

Adhesive for bonding Fermacell flooring elements.

**Floating Floor**  
Fermacell flooring system with a resilient layer to provide acoustic isolation.

**Furring**  
Metal channels to even the surface and provide a true surface for the fixing of Fermacell boards.

**Glass Mineral Wool**  
Glass based product for improved thermal or acoustic insulation.

**Gypsum**  
Calcium sulphate dihydrate (CaSO<sub>4</sub>.2H<sub>2</sub>O).

**Honeycomb Sheets**  
Retaining sheet for Fermacell Honeycomb infill.

**Honeycomb Infill**  
Mass providing infill for Honeycomb sheets.

**H<sub>2</sub>O & HD Boards**  
Cement bonded board for moisture affected areas.

**H<sub>2</sub>O Surface Finish**  
For finishing H<sub>2</sub>O boards.

**Impact Sound**  
The impact directly onto a structure of short duration sound such as foot steps or slamming doors.

**Independent Wall Lining**  
A lining erected independently of the external walling.

**Internal Wall**  
Wall or partition dividing dwelling space into different functions but not separation between dwellings.

**Joint Tape**  
Tape within the bedding compound to reinforce a joint.

**Jointstik**  
Adhesive for bonding the edges of square edged Fermacell boards.

**Jointing**  
The use of joint filler to tapered edge Fermacell, or Jointstik to achieve a flush seamless surface on walls and ceilings.

**Masonry Partition**  
A brick or block partition.

**Mass Per Unit Area**  
Mass per unit area, or surface density, is expressed in kilograms per square metre (kg/m<sup>2</sup>).

**Metal Stud Partition (DIN standard)**  
A stud and sheet partition comprising a metal stud with channel framework lined both sides with sheet materials such as Fermacell. Metal studs to be at least .6mm gauge thick metal with a 50mm fixing face.

**Metal Stud Party Wall**  
A metal stud partition that separates multi occupancy dwellings.

**Mineral Wool**  
Rock based mineral material manufactured in a quilt or batt form.

**Nogging**  
Cross member between main members of a framed construction.

**Noise**  
Unwanted sound leading to distraction and disturbance, interference with speech and stress or damage to hearing.

**Nominal Density**  
The density in the robust detail with a tolerance of up to -0.3kg/m<sup>2</sup> per layer.

**Partition**  
A non-loadbearing vertical construction dividing space.

**Perimeter Strip**  
Fibre mineral strip to reduce flanking transmission between Fermacell flooring elements and walls.

**Primer Sealer**  
For priming and sealing Fermacell boards prior to Fermacell waterproofing system.

**Reverberation**  
Presence of sound in an enclosure through its continual reflection or scattering from surfaces or objects after the sound source has ceased.

**RW**  
A (weighted) single-number quantity characterising airborne sound insulation of a building element derived from laboratory measurements (excluding flanking elements). BS EN ISO 717-1:1997 applies.

**RW + CTR**  
Weighted airborne sound insulation of a building using spectrum adaptation term (No 2) from BS EN ISO 717-1: 1997 representing 'A' weighted urban noise.

#### Robust Detail

Following a minimum of 30 field tests resulting in a recorded mean performance 5dB better than the sound insulation requirements as described in Approved Document E for new build separating walls and floors, a robust detail for Part E of the Building Regulations is given the status RD.

**Shrinkage**  
Caused by the evaporation of water from Joint Filler.

**Self-drilling, Self-tapping**  
Shank and point design of metal screws that give penetration and grip into light gauge metal section.

**Self Levelling Compound**  
For levelling uneven floors.

**Separating Floor**  
A floor that separates adjoining dwellings.

**Separating Wall**  
A wall that separates adjoining dwellings.

**Shaftwall**  
Partitions or linings that form fire protective enclosures to lift shafts and service cores.

**Sheathing Board**  
Sheath material fixed to external wall frameworks to assist with weather protection and to a degree of racking resistance.

**Skin**  
A single thickness of panelling or cladding or one leaf of a cavity wall.

**Soffit**  
Any semi exposed under surface.

**Sound Absorption**  
The loss of sound when striking or transmitting into a boundary surface material or obstacle, or when a volume of air resonates.

**Sound Leakage**  
Airborne sound transmission via gaps or cracks that allows sound to escape from one area to another so lowering potential sound reduction properties.

**Spatular**  
Blade to apply Fine Surface Treatment.

**Square Edge Boards**  
Fermacell boards with a square edge profile.

**Standard Level Different**  
The different in sound level for a stated frequency between source and receiving rooms corrected for the reverberation time in the receiving room. Expressed in Dnt. BS EN ISO 140-4: 1998 applies.

**Stud**  
Vertical member in a framed wall or partition.

**Suspended Ceilings**  
Ceilings formed of boards or tiles attached to a grid below the structural soffits joists or trusses.

**Tapered Edge**  
Fermacell board with edges for jointing using Joint Filler and tape available two sided and four sided.

**Timber Stud Partition**  
Partitions comprising timber frames lined with Fermacell.

**Trickle Protection Sheet**  
For use under Fermacell flooring systems.

**Vapour Control Layer**  
A membrane that substantially reduces the transfer of water vapour through a building element in which it is incorporated.

**Waterproofing Application**  
For sealing Fermacell boards in wet areas.

**Weighted Standardised Level Difference (1)**  
A single number weighted quantity characterising the airborne sound insulation between two rooms. Expressed in Dntw. BS EN ISO 717-1: 1997 applies.

**Weighted Standardised Level Difference (2)**  
The airborne sound insulation characteristics between two rooms using spectrum adaptation term (2) from BS EN ISO 717-1: 1997 representing 'A' urban noise.

**Working Time**  
The amount of time during which Joint filler is workable.



Fermacell UK  
7 The Priory  
Old London Road  
Canwell  
Sutton Coldfield  
B75 5SH  
Telephone: 0121 311 3480  
Fax: 0121 311 1882  
E-Mail: fermacell-uk@xella.com

All information and data is correct at the time of going to print. We reserve the right to make technical changes at any time.

[www.fermacell.co.uk](http://www.fermacell.co.uk)

**fermacell**<sup>®</sup>

## A European business

The fermacell product range is today manufactured in 5 factories across Germany, the Netherlands and Spain.

With sales operations across Europe and one in the Middle East, fermacell products are used in construction projects from Aberdeen to Sicily and from Madrid to Warsaw. UK and international case studies demonstrate that construction industry professionals across Europe understand and value fermacell as the "ultimate building board".

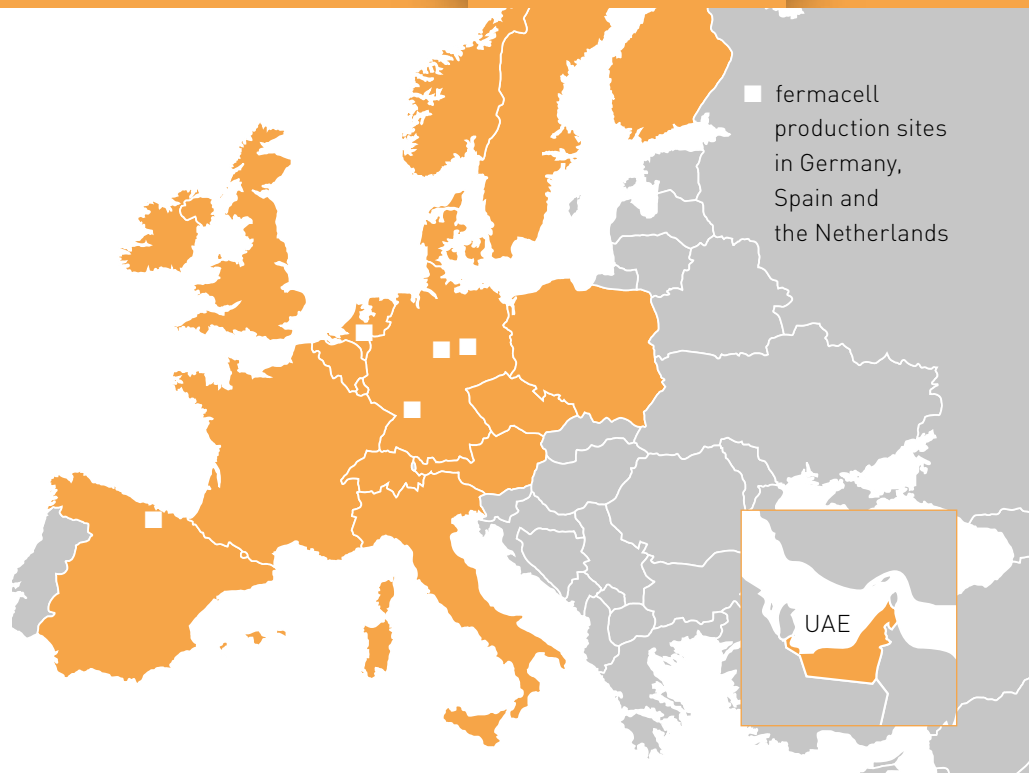

Orejo Factory, Spain



Calbe Factory, Germany



Wijchen Factory, the Netherlands